

with integrated process controller

Compact digital positioner for pneumatic valves with integrated process controller.

- Combination of positioner and process controller
- Compact solution for local control tasks
- Suitable for fast controlled systems
- Sampling rate 20 Hz, cycle time 50 ms
- Internal or external setpoint setting
- LED-display easy to read
- Sensor signal analogue as well as PT100
- Can be configured as P-, PI-, PD- and PID-controller
- Integrated stroke feedback without exposed parts
- Big stroke range 0.12 - 1.10" / 0.12 - 1.97"
- Self learning adaption to valve actuator
- Configuration and diagnosis functions via PC-software
- Not vulnerable to vibrations
- Protection class IP 65
- Also available for part turn actuators (single or double acting)



Technical Information

nominal stroke	0.12 - 1.10" / 0.12 - 1.97"
voltage of the working resistance	3,5 V (175 Ω @ 20 mA)
ambient temperature	+14 up to +165°F
Control variable (actual value)	0/4 - 20 mA, PT100 (2 or 3-wire)
Reference variable (set point)	via keyboard or 0/4 - 20 mA, 0/2 - 10 V
Control behaviour	P (with working point y0) PD (with working point y0) PI PID
Accuracy	≤ 0,5% of the end value
Input filter control variable	OFF, 20 ms; (Pt100: 200 ms) ON, T = 800 ms
Alarm output	absolut direct/invers, relativ direct/invers, Band direct/invers
auxiliary energy, electric	24 VDC ± 10%, max. 10 W
adjustment of stroke and zero point	self-learning
configuration	with control panel or PC-Software
auxiliary energy, pneumatic	max. 87 psi
air delivery* linear drive	40 NI/min
consumption of auxiliary energy in the controlled state	< 0,06 NI/min
Leakage	< 0,01 NI/min
air quality according ISO 8573-1:	
max. particle size and density:	Class 5
oil content	Class 4
pressure dew point	Class 3
	min. 20K (36°F) under ambient temperature
Actuation gas	compressed air or non flammable gases (nitrogen, CO ₂ ,...)
mounting to control valve	standardized mounting kits (also with optical position indicator)
pressure supply port	NPT 1/8"
protection class acc. DIN 40050	IP 65 (additional over pressure in the body with scavenging air)

* at 73 psi pilot pressure

Functional description

The 8049-IPC with integrated process controller offers a solution for demanding control tasks without higher-level process control systems. The basis of the 8049-IPC is the proven positioner 8049 in the 4-wire version. One additional IPC-module in the cover plate of the basic unit forms the complete unit of the 8049-IPC. The connection of a process sensor as reference variable, optionally as 0/4-20 mA sensor or PT-100 element, is made directly at the 8049-IPC. The setpoint can be specified either externally or directly on the module with scalable display. Scaling of the 8049-IPC as a P, PI, PD or PID controller offers the optimum solution for every process, especially in combination with valve technology from Schubert & Salzer. The process-related control parameters can be set either directly on the 8049-IPC or via the software DeviceConfig. Based on the control parameters, the IPC module calculates the difference between the reference variable and the setpoint. In parallel, the process controller supplies the positioner in 50 ms cycles with the control signal required for positioning. Thus, each control difference results in a change of the valve stroke.

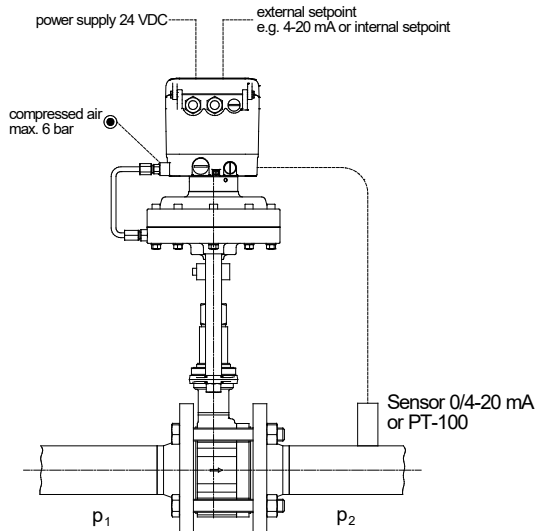

Connection example Pt-100

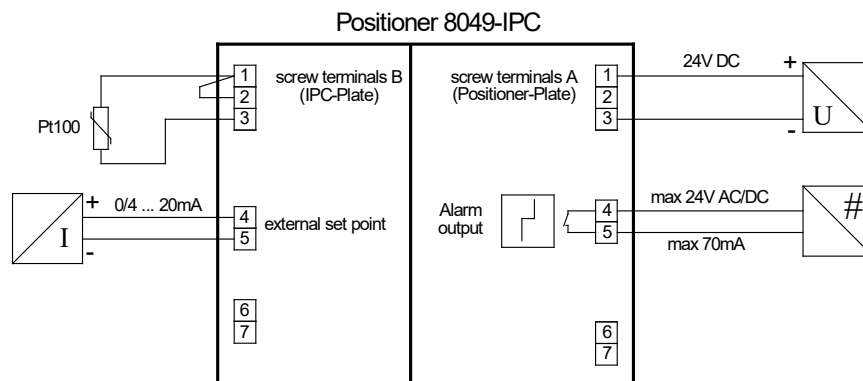

Connection example mA-sensor

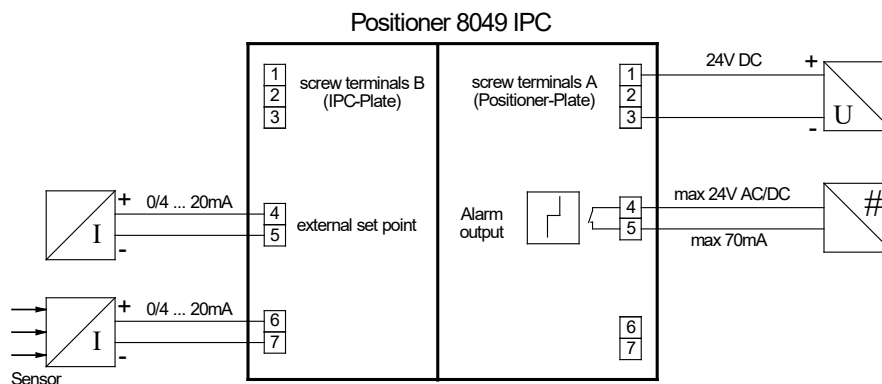

Ordering number system

										quote only if required			
8049/		-									S	-	
Basic design													
dig. positioner 8049-4 (version 5)											4P5		
For actuator													
single acting											1		
double acting											2		
Air delivery													
standard											S		
high											H		
Body													
aluminium / plastic											0		
stainless steel ground plate											1		
body in stainless steel											2		
Electro-pneumatic connection													
cable bushing 2 x M16x1,5											0		
NPT-thread 1/2"											1		
plug connection M12x1, 5-pin											2		
Pneumatic connection													
G 1/8"											0		
NPT 1/8"											1		
Position measuring													
linear potentiometer without sensing pin											0		
linear potentiometer with standard sensing pin (L=3,92")											1		
linear potentiometer with curtaed sensing pin (L=3,72")											G		
rotary potentiometer for semi-rotary drive											2		
EMV-galvanic separating module for exterior path sensor											3		
Optical indicator													
without indicator											0		
indicator disc for sensing pin in PA											1		
indicator disc for sensing pin in metal											2		
rotation angle indicator											3		
Auxiliary module													
without auxiliary module											0		
IPC-process controller											C		
Accessories													
without accessories											0		
gauge bloc single acting, scaling in bar and PSI											1		
optical position indicator for rotating actuators											2		
Further details													
special design (quote only if required)											S		
positioner montage (only for the manufacturer)											M		
Settings													
standard											-		
settings on customer request											1		
Special design													
without											-		
separated version incl. exterior path sensor for lift drive											1		

Dimensions

For linear actuators

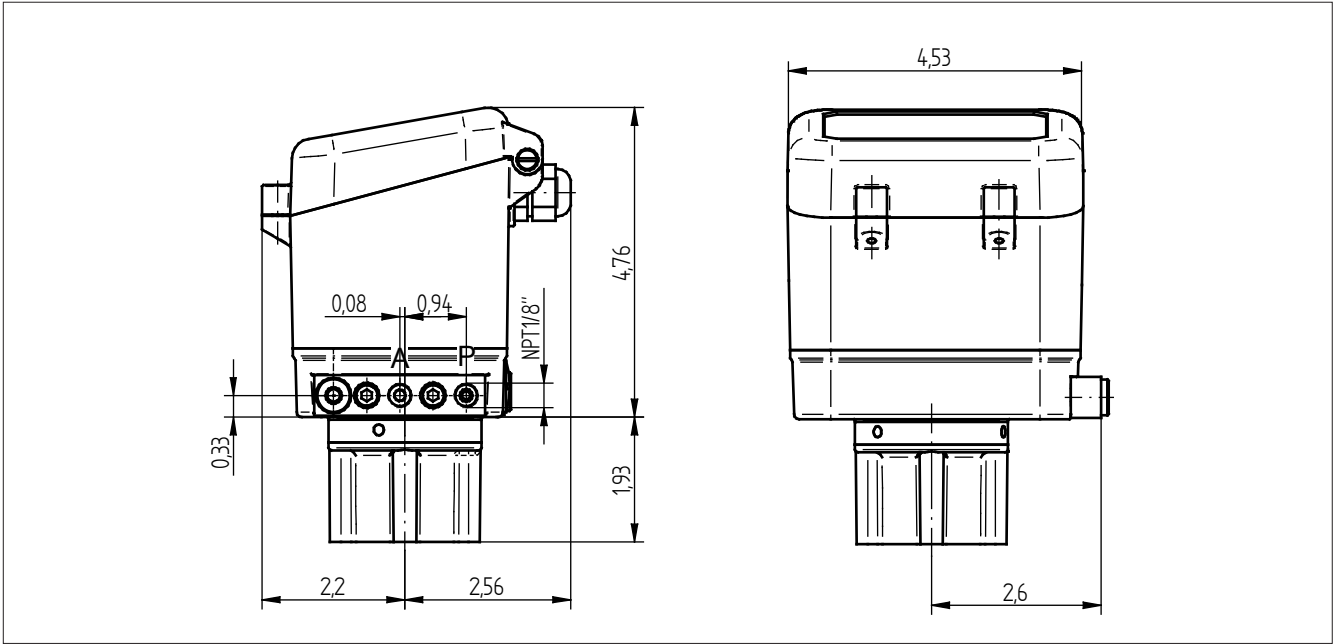

For quarter-turn actuators

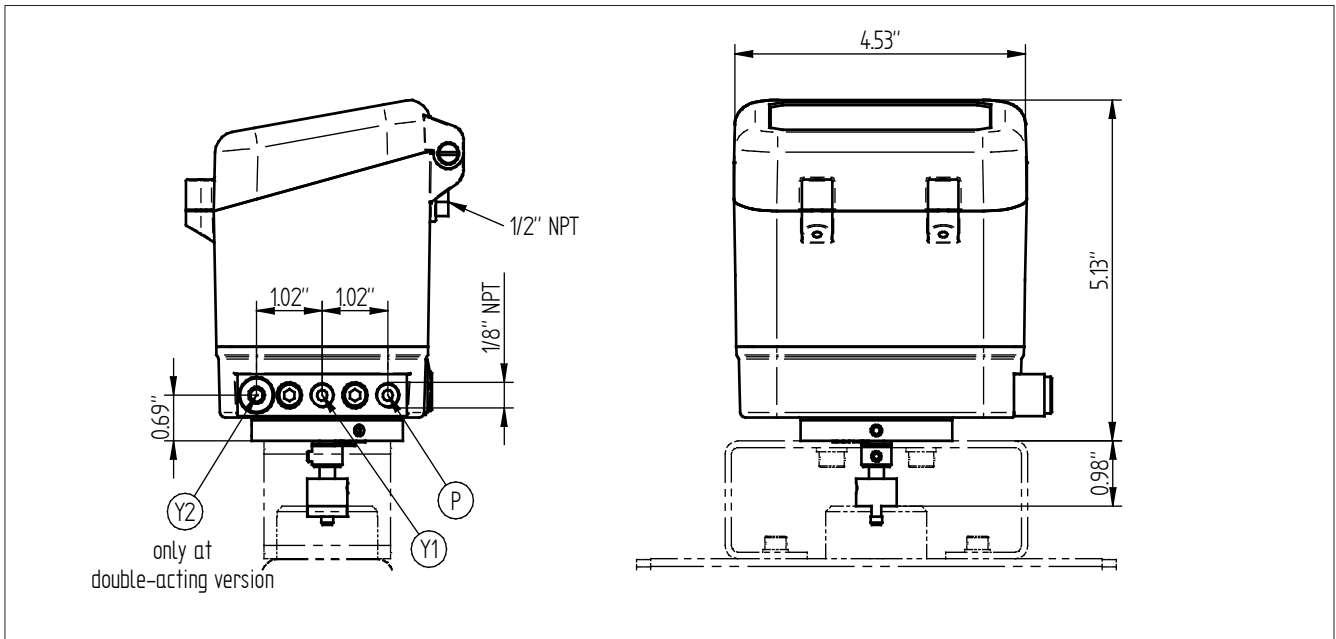

Configuration-Software „DeviceConfig“

Setup-Parameters

Adjustment of control parameters (input signal, stroke limitation, closing function, control hysteresis, valve function, etc.)

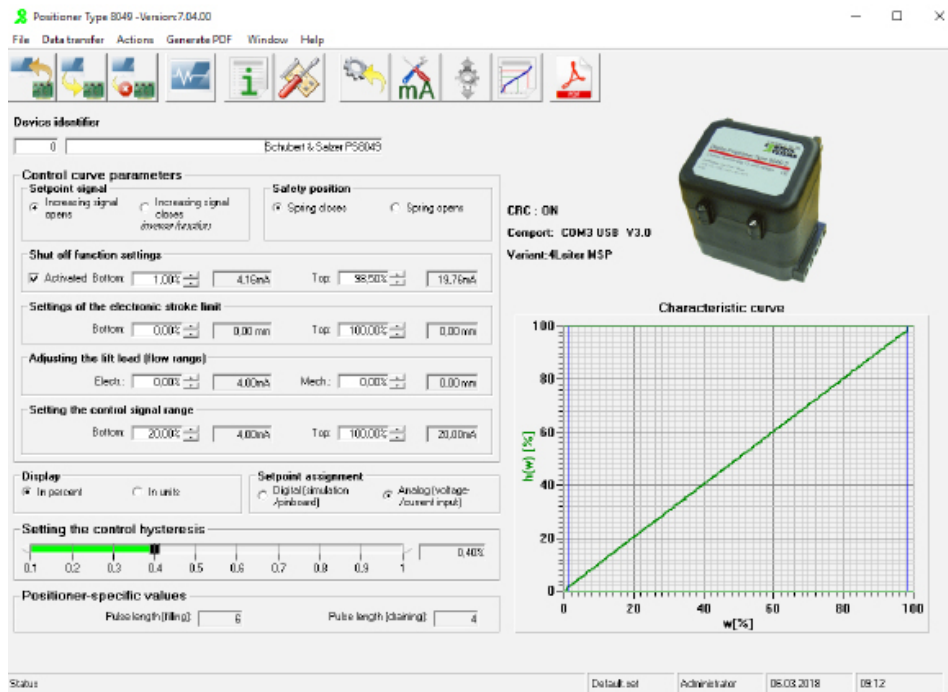

Live-Monitor

The operating conditions of the positioner, can be viewed with the live monitor.

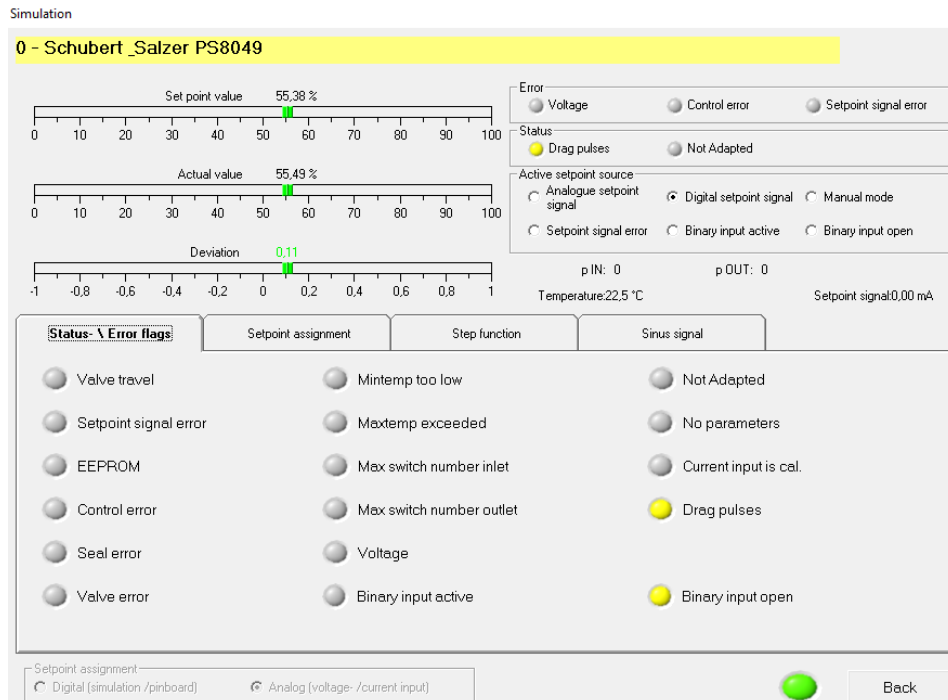

Configuration-Software „DeviceConfig“

Settings of the IPC-Modul parametrization of the IPC-module

IPC

Settings
Information
Monitor

IPC settings

ALAr - alarm-setpoint value:

HIST - alarm hysteresis: In physical unit

PASS - password: Negative value = complete lock

IPC: ON OFF

InPu - source of actual value:

Sub-menu-USER -> _____

Ctrl - control function: d - direct i - inverse

SEIP - source of setpoint value:

Internal setpoint value:

tALr - Type of alarm:

FILT - Filter: ON OFF

Sub-menu-PId -> _____

Mode: Automatic mode Manual mode

Only IPC extension

Generate IPC PDF
Load adjustments

Factory reset
Save adjustments

Sub-menu USER - scaling of input values

dEC - decimal points: 0..2

Lo - Lower setpoint value and actual value: In physical unit

Hi - Upper setpoint value and actual value: In physical unit

Sub-menu PId -controller parameter

bp -proportional range: 1,0 .. 99,99%

tn - integral time: 1 .. 4999 sek ; 5000 = OFF

td - derivative time: 1 .. 2999 sek ; 0 = OFF

y0 - operating point: 0 .. 100% (only if tn = OFF)

Back

Diagnostic data

Informations of valve stroke, running time, soft- and hardware-versions, achieved temperature- and stroke levels, error messages, number of cycles, operating hours...

Diagnosis

Base	Version information	Temperature- /way classes	Status / Error	Maintenance	Diagnosis																																	
		<p>Way classes</p> <table border="1" style="width: 100%; border-collapse: collapse;"> <thead> <tr> <th>Class</th> <th>Range</th> <th>No. hours</th> </tr> </thead> <tbody> <tr><td>W1:</td><td>0 ./ 10%</td><td><input type="text" value="232"/></td></tr> <tr><td>W2:</td><td>11 ./ 20%</td><td><input type="text" value="17"/></td></tr> <tr><td>W3:</td><td>21 ./ 30%</td><td><input type="text" value="15"/></td></tr> <tr><td>W4:</td><td>31 ./ 40%</td><td><input type="text" value="7"/></td></tr> <tr><td>W5:</td><td>41 ./ 50%</td><td><input type="text" value="7"/></td></tr> <tr><td>W6:</td><td>51 ./ 60%</td><td><input type="text" value="8"/></td></tr> <tr><td>W7:</td><td>61 ./ 70%</td><td><input type="text" value="16"/></td></tr> <tr><td>W8:</td><td>71 ./ 80%</td><td><input type="text" value="9"/></td></tr> <tr><td>W9:</td><td>81 ./ 90%</td><td><input type="text" value="13"/></td></tr> <tr><td>W10:</td><td>91 ./ 100%</td><td><input type="text" value="57"/></td></tr> </tbody> </table>	Class	Range	No. hours	W1:	0 ./ 10%	<input type="text" value="232"/>	W2:	11 ./ 20%	<input type="text" value="17"/>	W3:	21 ./ 30%	<input type="text" value="15"/>	W4:	31 ./ 40%	<input type="text" value="7"/>	W5:	41 ./ 50%	<input type="text" value="7"/>	W6:	51 ./ 60%	<input type="text" value="8"/>	W7:	61 ./ 70%	<input type="text" value="16"/>	W8:	71 ./ 80%	<input type="text" value="9"/>	W9:	81 ./ 90%	<input type="text" value="13"/>	W10:	91 ./ 100%	<input type="text" value="57"/>			
Class	Range	No. hours																																				
W1:	0 ./ 10%	<input type="text" value="232"/>																																				
W2:	11 ./ 20%	<input type="text" value="17"/>																																				
W3:	21 ./ 30%	<input type="text" value="15"/>																																				
W4:	31 ./ 40%	<input type="text" value="7"/>																																				
W5:	41 ./ 50%	<input type="text" value="7"/>																																				
W6:	51 ./ 60%	<input type="text" value="8"/>																																				
W7:	61 ./ 70%	<input type="text" value="16"/>																																				
W8:	71 ./ 80%	<input type="text" value="9"/>																																				
W9:	81 ./ 90%	<input type="text" value="13"/>																																				
W10:	91 ./ 100%	<input type="text" value="57"/>																																				
		<p>Temperature classes</p> <table border="1" style="width: 100%; border-collapse: collapse;"> <thead> <tr> <th>Class</th> <th>Range</th> <th>No. hours</th> </tr> </thead> <tbody> <tr><td>T1:</td><td>< -30 °C</td><td><input type="text" value="0"/></td></tr> <tr><td>T2:</td><td>-30./-15 °C</td><td><input type="text" value="0"/></td></tr> <tr><td>T3:</td><td>-15./0 °C</td><td><input type="text" value="0"/></td></tr> <tr><td>T4:</td><td>0./15 °C</td><td><input type="text" value="0"/></td></tr> <tr><td>T5:</td><td>15./30 °C</td><td><input type="text" value="190"/></td></tr> <tr><td>T6:</td><td>30./45 °C</td><td><input type="text" value="331"/></td></tr> <tr><td>T7:</td><td>45./60 °C</td><td><input type="text" value="1"/></td></tr> <tr><td>T8:</td><td>60./75 °C</td><td><input type="text" value="0"/></td></tr> <tr><td>T9:</td><td>75./85 °C</td><td><input type="text" value="0"/></td></tr> <tr><td>T10:</td><td>> 85 °C</td><td><input type="text" value="0"/></td></tr> </tbody> </table>	Class	Range	No. hours	T1:	< -30 °C	<input type="text" value="0"/>	T2:	-30./-15 °C	<input type="text" value="0"/>	T3:	-15./0 °C	<input type="text" value="0"/>	T4:	0./15 °C	<input type="text" value="0"/>	T5:	15./30 °C	<input type="text" value="190"/>	T6:	30./45 °C	<input type="text" value="331"/>	T7:	45./60 °C	<input type="text" value="1"/>	T8:	60./75 °C	<input type="text" value="0"/>	T9:	75./85 °C	<input type="text" value="0"/>	T10:	> 85 °C	<input type="text" value="0"/>			
Class	Range	No. hours																																				
T1:	< -30 °C	<input type="text" value="0"/>																																				
T2:	-30./-15 °C	<input type="text" value="0"/>																																				
T3:	-15./0 °C	<input type="text" value="0"/>																																				
T4:	0./15 °C	<input type="text" value="0"/>																																				
T5:	15./30 °C	<input type="text" value="190"/>																																				
T6:	30./45 °C	<input type="text" value="331"/>																																				
T7:	45./60 °C	<input type="text" value="1"/>																																				
T8:	60./75 °C	<input type="text" value="0"/>																																				
T9:	75./85 °C	<input type="text" value="0"/>																																				
T10:	> 85 °C	<input type="text" value="0"/>																																				

Back

Text and pictures are not binding. We reserve the right, to alter the equipment.