

GS 1 series - DN 15 up to DN 150

Pneumatic control valve with integrated positioner for regulating liquid and gaseous media for industrial applications

- Space saving design and low weight
- Fast response due to short strokes
- High Kvs- (Cv)- values
- Tight shut - off even at higher temperatures
- No exposed moving parts
- No steady- state air consumption
- Operation independent of mounting position and supply pressure variations
- Not sensitive to vibration
- Instrument grade air not essential
- Software configurable flow characteristics
- Protection Class IP65
- Meets the requirements of TA-Luft 2021



Technical Information

Body design	flangeless, wafer-type construction dimensions acc. DIN EN 558-1 series 20 for flanges acc. DIN EN 1092-1 form B more versions see data-sheet 8043-GS3		
Nominal sizes	DN 15 to DN 150		
Nominal pressure	PN 40 according DIN 2401, also for flanges PN 10 - PN 25		
Fluid temperature	body 1.0619	-10°C to +350°C	
	body 1.4581	-60°C to +350°C	
Ambient temperature*	digital positioner -10°C up to +75°C analog positioner -15°C up to +60°C		
Flange gaskets (customer side)	DIN EN 1514-1 or ANSI B16.21 in the respective nominal pressure rating		
Rangeability / Characteristic	25 : 1		
analog positioner	30 : 1		
digital positioner			
Leakage	Disc pair Carbon-stainless steel	Disc pair SFC	Disc pair STN 2
% of Kvs	< 0,0001	< 0,0005	< 0,001
IEC 60534-4	IV-S1	IV-S1	IV
EN 12266-1	E	F	F
Marking ATEX non electric	II 2G Ex h IIC T6...T1 X Gb II 2D Ex h IIIC 85°C...350°C X Db		
Packing leakage	ISO FE - BH - CC3 - SSA0 - t (-40°C / +350 °C) - PN40 - ISO 15848-1		

* Please consider the limitation of use of the positioner!

** With DN15 with reduction of less than 25%, different leakage rates possible.
Kvs-values see data sheet 8001.

Materials

Body	carbon steel 1.0619	stainless steel 1.4408	
Bonnet	brass, chrome-plated (Ø 80 mm actuator), aluminium anodised (actuator Ø 125 mm)		
Actuator springs	stainless steel 1.4310 (Ø 80 mm actuator); spring steel wire C, plastic coated (actuator Ø 125 mm)		
Packing	PTFE carbon filled (spring 1.4310)		
Actuating stem	stainless steel 1.4571, roller burnished		
Bellows	stainless steel 1.4571		
Fixed disc	stainless steel 1.4581, coated		STN2 - disc
Sliding disc	special carbon material	SFC - disc (max. 300°C)	STN2 - disc
Coupling ring for disc	stainless steel 1.4581		
Window for positioner indicator	PA Trogamid (clean)		

Positioner

For technical information of our positioners please refer to the corresponding data sheets.

**Admissible differential pressure
(For temperatures of up to 120°C)
digital positioner, Type 8049**

(also on-off valves and valves with other side-mounted positioner)

Disc-pair: carbon - stainless steel coated

SFC - stainless steel coated

DN	actuator	max. differential pressures		pilot pressures
		control, on/off		
15	80	40		3,5 - 6
20	80	40		3,5 - 6
25	80	40		3,5 - 6
32	80	40		4,0 - 6
40	80	30,4		4,0 - 6
50	80	19,5		4,5 - 6
65	80	16,3		4,5 - 6
80	80	10,2		5,0 - 6
100	80	6,5		5,0 - 6
125	80	4,4		5,0 - 6
150	80	3,3		5,0 - 6

15	125	40		3,0 - 6
20	125	40		3,0 - 6
25	125	40		3,0 - 6
32	125	40		3,0 - 6
40	125	40		3,0 - 6
50	125	40		3,5 - 6
65	125	37,6		3,5 - 6
80	125	23,6		4,0 - 6
100	125	15		4,0 - 6
125	125	10,1		4,0 - 6
150	125	7,5		4,0 - 6

p/p- and i/p-positioner, Type 8047

Disc-pair: carbon - stainless steel coated

SFC - stainless steel coated

DN	actuator	max. differential pressures		pilot pressures
		Regelung	on/off	
15	80	40	40	3,0 - 6
20	80	39,8	36,6	3,5 - 6
25	80	29,5	30,7	3,5 - 6
32	80	21,8	25,1	4,0 - 6
40	80	14,9	19	4,0 - 6
50	80	8,8	12,5	4,5 - 6
65	80	7,2	10,5	4,5 - 6
80	80	4,4	6,7	4,5 - 6
100	80	2,7	4,3	4,5 - 6

15	125	40	40	3,0 - 6
20	125	40	40	3,0 - 6
25	125	40	40	3,0 - 6
32	125	40	40	3,0 - 6
40	125	34,3	40	3,0 - 6
50	125	20,4	27,1	3,5 - 6
65	125	16,7	22,8	3,5 - 6
80	125	10,1	14,5	3,5 - 6
100	125	6,2	9,3	3,5 - 6
125	125	4,2	6,3	3,5 - 6
150	125	3,1	4,7	3,5 - 6

**For temperatures of 120°C and above: obey
application limits !**

Disc pair: STN2

DN	actuator	max.differential pressures		pilot pressures
		control, on/off		
15	80	40		3,5 - 6
20	80	37,3		4,0 - 6
25	80	27,4		4,0 - 6
32	80	20,1		4,5 - 6
40	80	13,6		4,5 - 6
50	80	8		5,0 - 6
65	80	6,6		5,0 - 6
80	80	4		5,0 - 6
100	80	2,4		5,0 - 6

15	125	40		3,0 - 6
20	125	40		3,0 - 6
25	125	40		3,0 - 6
32	125	40		3,5 - 6
40	125	27		3,5 - 6
50	125	18,5		4,0 - 6
65	125	15,1		4,0 - 6
80	125	9,1		4,0 - 6
100	125	5,6		4,0 - 6
125	125	3,8		4,0 - 6
150	125	2,8		4,0 - 6

Disc pair: STN2

DN	actuator	max.differential pressures		pilot pressures
		control	on/off	
15	80	28,4	29,9	3,5 - 6
20	80	19,3	23	4,0 - 6
25	80	13,1	17,2	4,0 - 6
32	80	9,1	12,8	4,0 - 6
40	80	5,9	8,8	4,0 - 6
50	80	3,4	5,3	4,5 - 6
65	80	2,7	4,3	4,5 - 6

15	125	40	40	3,0 - 6
20	125	40	40	3,0 - 6
25	125	30,2	37,4	3,0 - 6
32	125	21	27,8	3,0 - 6
40	125	13,7	19,1	3,0 - 6
50	125	7,8	11,4	3,5 - 6
65	125	6,3	9,4	3,5 - 6
80	125	3,7	5,7	3,5 - 6
100	125	2,3	3,5	3,5 - 6

**Admissible differential pressure
(For temperatures of up to 120°C)**

**For temperatures of 120°C and above:
obey application limits !**

**Actuator D80 double acting
without safety position
digital positioner, type 8049-4 wire**

Nominal size	Max. differential pressure at actual pilot pressure [bar]															
	Disc pair: carbon/SFC-stainless steel coated								Disc pair: STN							
	2,5	3,0	3,5	4,0	4,5	5,0	5,5	6,0	2,5	3,0	3,5	4,0	4,5	5,0	5,5	6,0
15	40,0	40,0	40,0	40,0	40,0	40,0	40,0	40,0	40,0	40,0	40,0	40,0	40,0	40,0	40,0	40,0
20	40,0	40,0	40,0	40,0	40,0	40,0	40,0	40,0	40,0	40,0	40,0	40,0	40,0	40,0	40,0	40,0
25	40,0	40,0	40,0	40,0	40,0	40,0	40,0	40,0	34,0	40,0	40,0	40,0	40,0	40,0	40,0	40,0
32	40,0	40,0	40,0	40,0	40,0	40,0	40,0	40,0	24,9	30,7	36,4	40,0	40,0	40,0	40,0	40,0
40	37,7	40,0	40,0	40,0	40,0	40,0	40,0	40,0	16,9	20,8	24,7	27,0	27,0	27,0	27,0	27,0
50	24,2	29,8	35,4	40,0	40,0	40,0	40,0	40,0	10,0	12,3	14,6	16,9	19,2	21,5	23,8	26,1
65	20,2	24,9	29,6	34,3	39,0	40,0	40,0	40,0	8,1	10,0	11,9	13,8	15,7	17,6	19,4	21,3
80	12,7	15,7	18,6	21,5	24,5	27,4	30,4	33,3	4,9	6,0	7,2	8,3	9,4	10,6	11,7	12,8
100	8,1	9,9	11,8	13,7	15,5	17,4	19,3	21,1	3,0	3,7	4,4	5,1	5,8	6,5	7,2	7,9
125	5,5	6,7	8,0	9,2	10,5	11,8	13,0	14,3	2,0	2,5	3,0	3,4	3,9	4,4	4,8	5,3
150	4,1	5,0	5,9	6,9	7,8	8,7	9,7	10,6	1,5	1,8	2,2	2,5	2,9	3,2	3,6	3,9

**Actuator D125 double acting
without safety position
digital positioner, type 8049-4 wire**

Nominal size	Max. differential pressure at actual pilot pressure [bar]															
	Disc pair: carbon/SFC-stainless steel coated								Disc pair: STN							
	2,5	3,0	3,5	4,0	4,5	5,0	5,5	6,0	2,5	3,0	3,5	4,0	4,5	5,0	5,5	6,0
15	40,0	40,0	40,0	40,0	40,0	40,0	40,0	40,0	40,0	40,0	40,0	40,0	40,0	40,0	40,0	40,0
20	40,0	40,0	40,0	40,0	40,0	40,0	40,0	40,0	40,0	40,0	40,0	40,0	40,0	40,0	40,0	40,0
25	40,0	40,0	40,0	40,0	40,0	40,0	40,0	40,0	40,0	40,0	40,0	40,0	40,0	40,0	40,0	40,0
32	40,0	40,0	40,0	40,0	40,0	40,0	40,0	40,0	40,0	40,0	40,0	40,0	40,0	40,0	40,0	40,0
40	40,0	40,0	40,0	40,0	40,0	40,0	40,0	40,0	27,0	27,0	27,0	27,0	27,0	27,0	27,0	27,0
50	40,0	40,0	40,0	40,0	40,0	40,0	40,0	40,0	26,3	32,0	37,7	40,0	40,0	40,0	40,0	40,0
65	40,0	40,0	40,0	40,0	40,0	40,0	40,0	40,0	21,5	26,1	30,8	35,4	37,6	37,6	37,6	37,6
80	33,6	40,0	40,0	40,0	40,0	40,0	40,0	40,0	12,9	15,7	18,5	21,3	22,0	22,0	22,0	22,0
100	21,3	24,8	24,8	24,8	24,8	24,8	24,8	24,8	8,0	9,7	11,5	13,2	13,4	13,4	13,4	13,4
125	14,4	16,4	16,4	16,4	16,4	16,4	16,4	16,4	5,3	6,5	7,6	8,8	8,9	8,9	8,9	8,9
150	10,7	13,0	15,3	16,0	16,0	16,0	16,0	16,0	3,9	4,8	5,6	6,5	7,3	8,2	9,0	9,9

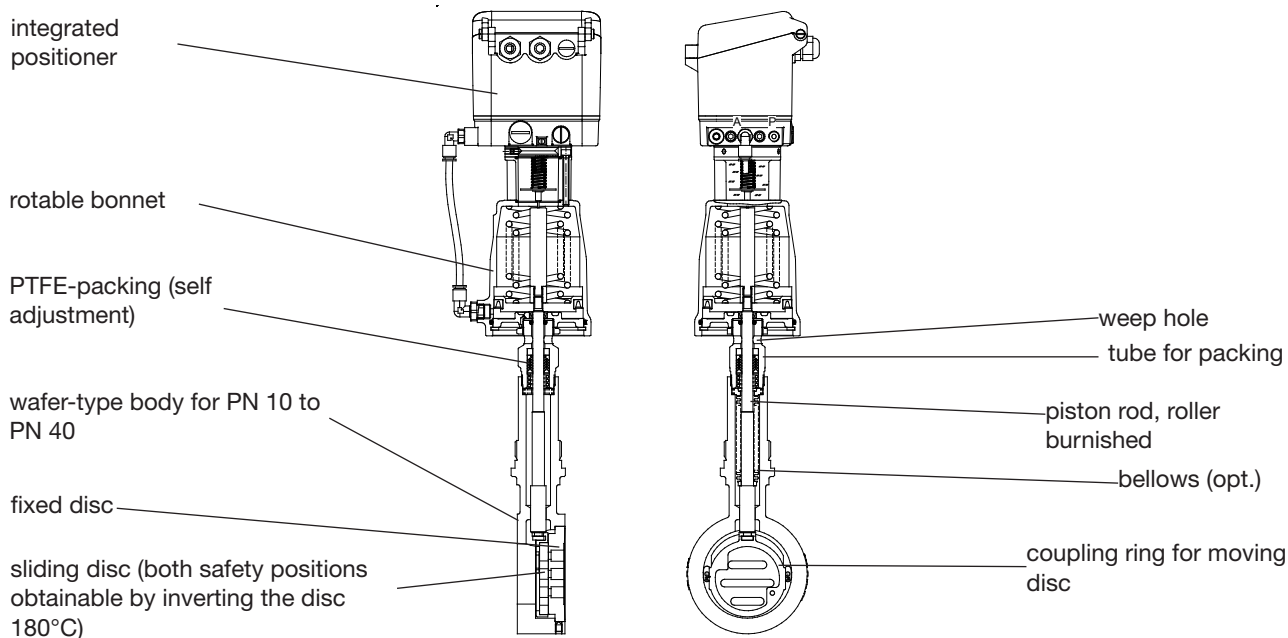

Applications limits for GS1-Valves made of stainless steel

PN 40

DN	Sliding unit: carbon/SFC - stainless steel, coated max. admissible pressures for GS1-valves						Sliding unit: carbon - STN2 max. admissible pressures for GS1-valves					
	100°C	150°C	200°C	250°C	300°C	350°C	100°C	150°C	200°C	250°C	300°C	350°C
15 - 25	40	36	31	28	26	24	40	36	31	28	26	24
32	40	36	31	28	26	24	40	36	31	28	25	22
40	40	36	31	28	26	24	26	25	24	19	16	14
50	40	36	31	28	26	24	40	36	31	28	26	24
65	40	36	31	28	26	24	37	35	31	27	22	19
80	40	36	31	28	26	24	22	20	19	16	13	11
100	24	23	22	19	17	16	13	12	12	9	8	6
125	16	15	14	13	11	10	8	8	7	6	5	4
150	16	16	16	16	14	13	10	10	9	7	6	5

Limitation for SFC-sliding discs: 300°C

Ordering Number System

8 0 4 3 / V F M Z S

1 2 3 4 5 6 7 8 9 10 11 12 13 14 15 16

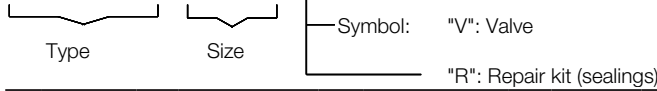

1 - 5 : Please quote all 5 sections
6 - 12: Quote only if required

1. Type	2. Connection	3. Body material	4. Safety position	5. Actuator	6. Special versions	7. Springs	8. Stem sealing
F sliding gate valve, long design (type 8043)	0 flangeless wafertype construction for flanges acc. DIN 2632-2635 (PN10-PN40)	0 carbon steel 1.0619 1 stainless steel 1.4408 2 carbon steel 1.0619 reduced design 3 stainless steel 1.4408 reduced design	0 spring closes 1 spring opens	1 piston 80 mm 2 piston 125 mm	M state, if further sections are quoted	- standard	- PTFE-packing, self adjusting (standard) 1 additional bellow 1.4571
9. Moving disc	10. Fixed disc	11. Kvs-values	12. Characteristic	13. Accessories	14. Positioner	15. Special versions	16. Further special versions
- carbon material 9 STN2/ STN3-disc S SFC-disc	- stainless steel 1.4571, coated 1 STN2-disc (only in combination with pos. „9“) 3 STN3-disc (only in combination with pos. „9“)	- 100% (Stand.) A red. to 63% 1 red. to 40% B red. to 25% 2 red. to 16% C red. to 10% 3 red. to 6,3% 4 red. to 2,5% 5 red. to 1% 6 red. to 20 % 7 red. to 12% 8 red. to 2% 9 red. to 0,4%	- linear 1 equal percentage	Z Accessories	2 p/p-positioner Type 8047 + pos.indic. 3 i/p-positioner Type 8047 + pos.indic. 5 i/p-positioner Type 8047 + pos.indic. Eex ibll CT6, with plug conn. M12x1 8 i/p-positioner Type 8047 + pos.indic. plug conn. M12x1 C digital positioner Type 8049, 4-wire R digital positioner Type 8049, 2-wire W digital positioner Type 8049 ExPro, ATEX, IECEX K digital positioner type 8049 ExPro-FM with base plate in stainless steel; Ta = -10°C to +75°C; IS Class I Division 1, Groups A, B, C, D; T4 Entity; Class I Zone 0 AEx ia IIC T4 Entity, IP65 N digital positioner Type 8049 IO-Link version Y digital positioner type 8049 ExPro-FM with base plate in stainless steel; Ta = -10°C to +75°C; NI Class I Division 2, Groups A, B, C, D; T4 NIFW, IP65	1 fittings and tubing made from PA E fittings and tubing made of stainless steel	S further special-versions

Ordering example:

8043/050VF0101M - - - - 1Z3

sliding gate valve type 8043, long design, DN 50, PN 10/40, stainless steel 1.4571, spring closes, actuator 80 mm, PTFE-V-shaped sealing rings, carbon material, stainless steel, seat characteristic equal percentage, i/p positioner with optical position indicator

Dimensions and Weights

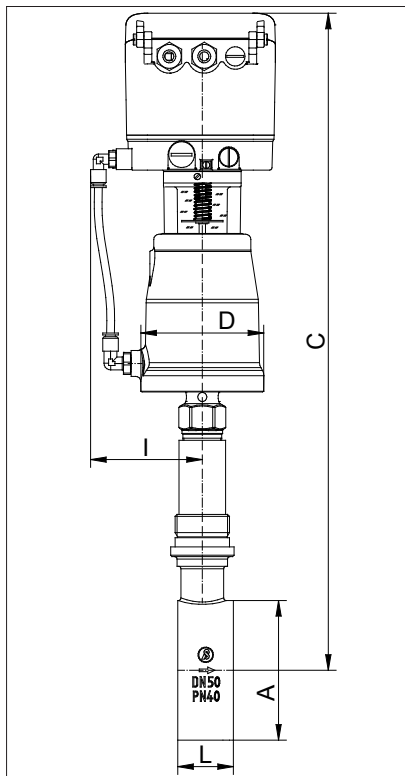

Type 8043 with digital positioner
Type 8049
with position indicator

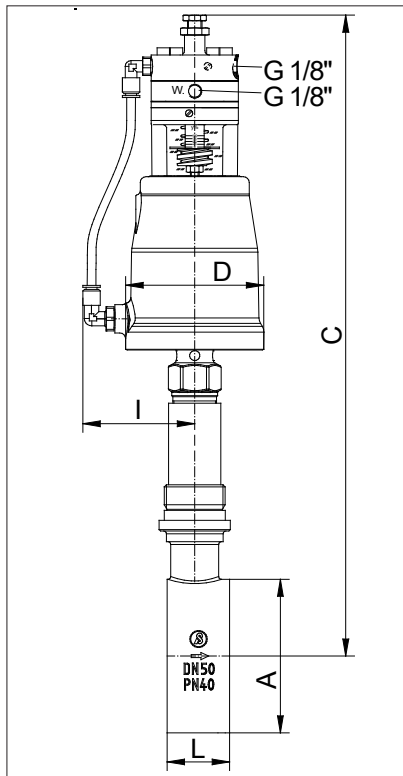

Type 8043 with p/p-positioner
Type 8047
with position indicator

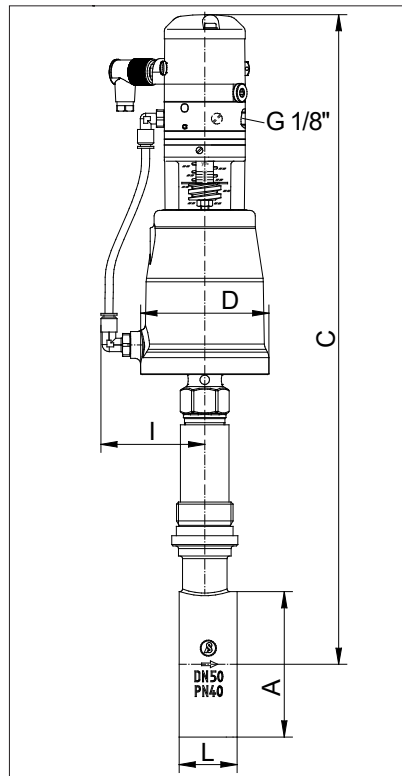

Type 8043 with i/p-positioner
Type 8047
with position indicator

DN	Piston Ø	A	D	I	L	C			Stroke H	Weight (kg)
						p/p positioner	i/p positioner	digital positioner		
15	80	53	96	89,5	33	422	454	484	6	5,6
15	125	53	146	102,5	33	442	474	504	6	7,4
20	80	62	96	89,5	33	427	459	488	6	5,7
20	125	62	146	102,5	33	447	479	508	6	7,5
25	80	72	96	89,5	33	432	464	493	6	5,8
25	125	72	146	102,5	33	452	484	513	6	7,6
32	80	82	96	89,5	33	436	468	495	6	5,8
32	125	82	146	102,5	33	456	488	515	6	7,6
40	80	92	96	89,5	33	441	473	501	6	6
40	125	92	146	102,5	33	461	479	521	6	7,8
50	80	108	96	89,5	43	451	483	509	8	7,1
50	125	108	146	102,5	43	471	503	529	8	8,9
65	80	126	96	89,5	46	461	493	518	8	7,6
65	125	126	146	102,5	46	481	513	539	8	9,4
80	80	142	96	89,5	46	469	501	527	8	8,3
80	125	142	146	102,5	46	489	521	547	8	10,1
100	80	164	96	89,5	52	481	513	540	8,5	9,5
100	125	164	146	102,5	52	501	533	560	8,5	11,3
125	80	194	96	89,5	56	496	528	555	8,5	13,2
125	125	194	146	102,5	56	516	548	575	8,5	15
150	80	219	96	89,5	56	511	543	570	8,5	15,1
150	125	219	146	102,5	56	531	563	590	8,5	16,9

Dimension C „reduced design“ shotened by 25,4 mm

Dimensions in mm