

Sliding Gate Motor Valve 8030



GS 1 series, DN 15 up to DN 150

Sliding gate motor valve for control and switching of neutral through to highly aggressive media in process engineering, chemical industries and for plant equipment.

- Space saving wafer type construction
- Lowest possible weight (especially in larger sizes)
- Low operation noise level (quiet operation)
- Control of high differential pressures with small actuators
- Fast response time
- Fail safe option
- Meets the requirements of TA-Luft 2021

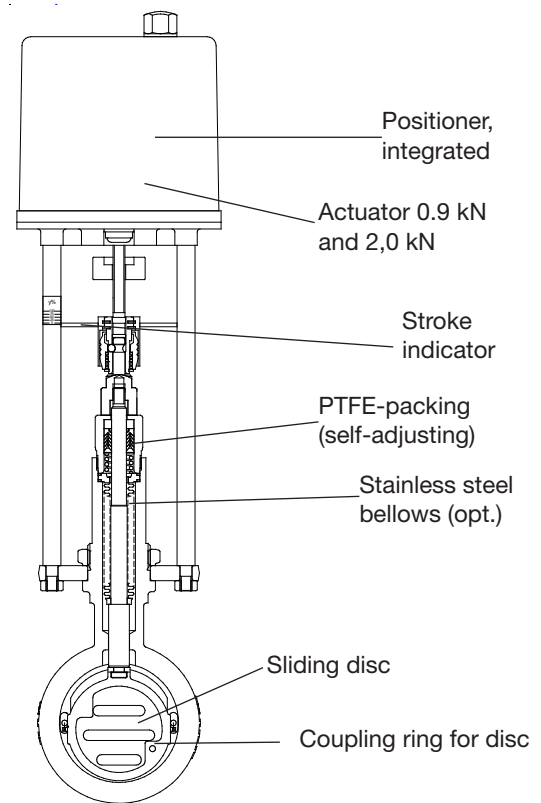
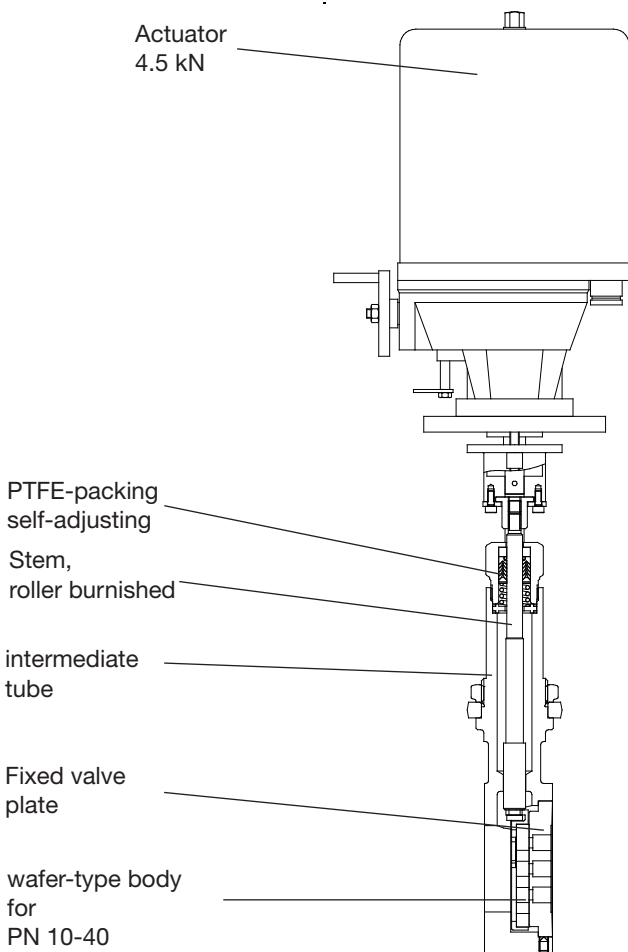

Technical information

Body material	flangeless, wafer type construction Dimensions acc. DIN EN 558-1 series 20 for flanges acc. DIN EN 1092-1 form B more versions see data-sheet 8030-GS3		
Nominal sizes	DN 15 up to DN 150		
Nominal pressure	PN 40 acc. DIN 2401 also for flanges PN 10 up to PN 25		
Fluid temperature	body 1.0570: -10°C up to +350°C body 1.4571: -60°C up to +350°C (+300°C for SFC)		
Flange gaskets (customer side)	DIN EN 1514-1 or ANSI B16.21 in the respective nominal pressure rating		
Rangeability	30 : 1		
Leakage	Disc Pair Carbon-stainless steel	Disc Pair SFC	Disc Pair STN2
% of Kvs IEC 60534-4 EN 12266-1	<0,0001 IV-S1 E	<0,0005 IV-S1 F	<0,001 IV F
Packing leakage	ISO FE - BH - CC3 - SSA0 - t (-40°C / +350 °C) - PN40 - ISO 15848-1		

* With DN15 with reduction of less than 25%, different leakage rates possible.
K_{vs}-values see data sheet 8001.

Technical information of the motor actuator

Driving force	0.9 kN; 2 kN; 4.5 kN
Type of duty (according VDE 0530)	S 1 - 100 % ED (0,9kN; 2kN; 4,5kN DC) S 4 - 30 % ED (0.45 kN; 0.9 kN; 2 kN) S 4 - 30 % ED 600c/h (4.5 kN)
Power connections	24 V AC 24 V DC 110/120V AC 230 V AC 400 V 3-phase-AC other on request
Ambient temperature	0°C up to +60°C; - 20°C up to + 60°C with heating resistor element
Mounting position	free choice, but motor not vertical down
Protection class (Din 40050)	IP 65 (0,9 kN; 2 kN; 4.5 kN)

Materials

Body	Carbon steel 1.0619	Stainless steel 1.4408	
Packing	PTFE (carbon filled), spring 1.4310		
Actuating stem	Stainless steel, roller burnished		
Bellow	Stainless steel 1.4571		
Fixed plate	Stainless steel 1.4571, plated		STN2-disc
Sliding disc	Standard: special carbon material	SFC-disc	STN2-disc
Coupling ring for discs	Stainless steel 1.4581		

Stroking times (sec.):

	0,9 kN	2,0 kN	4,5 kN
Stroking speed mm/min	10	9,2	24
DN 15 - 40	36	28	15
DN 50 - 80	47	38	20
DN 100 - 150	50	40	21

Power consumption (Watt):

24 VAC, 230 VAC	5	6,6	40/28
24 VDC	10	20	30
400 V, 50 Hz	10	10	35
110/120 V AC	5	6,6	28

Options

Limit switches	max. 2	max. 2	max. 2
Potentiometer	1	1	max. 2*
Positioner, analogue	yes	yes	yes

* one potentiometer is required for positioner option

Optional stroking times

Driving force (kN)	0,9				2		4,5	
Stroking speed mm/min.	13,5	8	5,1	2,9	15,2	7,5	5,6	50
Nominal size	Stroking times (sec.)							
DN 15 - 40	28	47	74	129	25	50	67	7,5
DN 50 - 80	37	62	97	171	33	66	88	9,9
DN 100-150	39	66	103	181	35	70	94	10,5

Maximum Differential Pressures

DN	0,9 kN	2,0 kN	4,5 kN	0,9 kN	2,0 kN	4,5 kN
	carbon/SFC-stainless steel			STN2		
15	40	40	40	40	40	40
20	40	40	40	40	40	40
25	40	40	40	32	40	40
32	40	40	40	23	40	40
40	35	40	40	16	27	27
50	23	40	40	9	23	40
65	19	40	40	8	19	38
80	12	29	40	4,5	11	22
100	8	18	25	3	7	13
125	5	12	16	2	4,5	9
150	-	9	16	-	3	8

Applications limits for GS1-Valves made of stainless steel

PN 40

DN	Sliding unit: carbon/SFC - stainless steel, coated max. admissible pressures for GS1-valves						Sliding unit: carbon - STN2 max. admissible pressures for GS1-valves					
	100°C	150°C	200°C	250°C	300°C	350°C	100°C	150°C	200°C	250°C	300°C	350°C
15 - 25	40	36	31	28	26	24	40	36	31	28	26	24
32	40	36	31	28	26	24	40	36	31	28	25	22
40	40	36	31	28	26	24	26	25	24	19	16	14
50	40	36	31	28	26	24	40	36	31	28	26	24
65	40	36	31	28	26	24	37	35	31	27	22	19
80	40	36	31	28	26	24	22	20	19	16	13	11
100	24	23	22	19	17	16	13	12	12	9	8	6
125	16	15	14	13	11	10	8	8	7	6	5	4
150	16	16	16	16	14	13	10	10	9	7	6	5

Limitation for SFC-sliding discs: 300°C

Ordering Number System

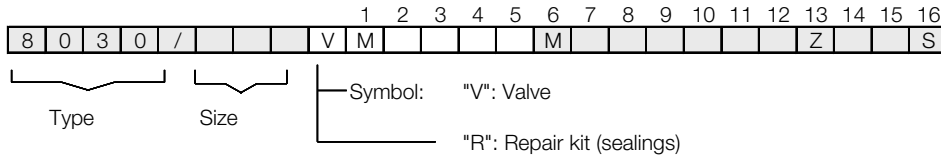

1 - 5 : Please quote all 5 sections.
6 - 16: Quote only if required.

1.	Type	2.	Connec-tion	3.	Body material	4.	Safety position	5.	Actuator thrust	6.	Special versions	7.	Voltages	8.	Stem sealing
M	GS-motor valve type 8030	0	flangeless design for flanges acc. DIN 2632-2635 (PN10-PN40)	0	carbon steel 1.0619	-	without	4	0,9 kN - IP65 2,0 kN - IP65 4,5 kN - IP65	M	state, if further sections are quoted	-	230 V AC (standard)	-	PTFE-packing, self adjusting (standard)
				1	stainless steel 1.4408							1	24 V AC		
												2	400 V, 50 Hz 3-phase current	1	Additional bellow 1.4571
												3	24 V DC		
												4	110/120V AC for 0,9kN, 2kN and 4,5kN		

9.	Moving disc	10.	Fixed plate	11.	Kvs-values	12.	Charac-teristic	13.	Acces-sories	14.	Limit swit-ches	15.	Feedback	16.	Special versions
-	Carbon material	-	Stainless steel 4571, coated	-	100% (Stand.)	-	linear	Z	Acces-sories	-	none	-	without	S	Further special versions
9	STN2-disc	1	STN2-plate	A	red. to 63%	1	equal percen-tage			1	1 stroke depen-dent limit switch	1	Potential-meter 1000 Ohm		
S	SFC-disc			B	red. to 40%					2	2 stroke depent limit swit-ches	C	Stroke feedback for positioner 0/4-20mA		
				2	red. to 25%										
				3	red. to 16%										
				C	red. to 10%										
				3	red. to 6,3%										
				4	red. to 2,5%										
				5	red. to 1%										
				6	red. to 20%										
				7	red. to 12%										
				8	red. to 2%										
				9	red. to 0,4%										

17.	Stroking time	18.		19.	Positioner
-	Standard	-		-	without
				3	0 - 10 V
				N	4 - 20 mA
				M	0 - 20 mA

Ordering examples:

8030/100VM00 - 1M1 - - - - Z2

GS-control valve with motor actuator, DN 100, flangeless wafer-type hyper construction, C-steel, driving force 2 kN, 24 V, 50 Hz A.C., PTFE V-shaped seal, carbon material metallicly impregnated, stainless steel 1.4581, Kvs-value 100 %, Seat characteristics linear, two limit switches.

Dimensions and Weights

DN	A	C~			L	Weight kg			Stroke
		0.9 kN	2.0 kN	4.5 kN		0.9 kN	2.0 kN	4.5 kN	
15	53	450	487	525	33	3,9	4,2	7,2	6
20	62	455	492	530	33	4,0	4,3	7,3	6
25	72	460	497	535	33	4,1	4,4	7,4	6
32	82	465	502	540	33	4,2	4,5	7,5	6
40	92	470	507	545	33	4,3	4,6	7,6	6
50	108	480	517	555	43	5,5	5,8	8,8	8
65	127	490	527	565	46	6,0	6,3	9,3	8
80	142	495	532	570	46	6,7	7,0	10,0	8
100	164	510	547	585	52	7,9	8,2	11,2	8,5
125	194	525	562	600	56	9,7	10,0	13,0	8,5
150	219	-	577	615	56	-	11,9	14,9	8,5

Dimensions in mm

