

# High Temperature Sliding Gate Valve 8024

## GS 3 series - DN15 up to DN250

**Pneumatic sliding gate valve optionally with integrated positioner for regulating or shutting off liquid and gaseous media for industrial high temperature applications**

- Space saving wafer type construction
- Lowest possible weight
- Quiet operation
- Fast response time
- Control of high differential pressures with small actuators
- Greatly reduced energy consumption rates due to short strokes and low actuating forces on the throttle element
- High Kvs-(Cv)-values
- Meets the requirements of TA-Luft 2021



### Technical Information

Body design	Flangeless, wafer-type construction		
Nominal sizes	DN 15 to DN 250		
Nominal pressure for flanges with facing type B	PN 40 (fits also to PN 10-25) PN 100 PN 16	DN 15 - DN 150 DN 15 - DN 80 DN 200 - DN 250	
Nominal pressure acc. ANSI for flanges acc. ASME B 16.5 RF	ANSI 150 ANSI 300 ANSI 600	DN15 - DN 250 DN 15 - DN 150 DN 15 - DN 80	
Nominal pressure acc. JIS for „raised face“ flanges	10 K 20K	DN 15 - DN 50 DN 15 - DN 40	
Supply air pressure	max. 6 bar		
Media temperature	-60°C up to +450°C for function unit Carbon-stainless steel -60°C up to +450°C for function unit STN2 -60°C up to +300°C for function unit SFC up to +530°C with stainless steel body, Inconel 625 bellows and STN 2 function unit		
Ambient temperature*	digital positioner -10°C up to +75°C analog positioner -15°C up to +60°C		
Rangeability	40 : 1		
Leakage **	Disc pair Carbon-stainless steel <0,0001 IV-S1 E < 0,0001	Disc pair SFC <0,0005 IV-S1 F < 0,0005	Disc pair STN 2 <0,001 IV F < 0,001
Marking ATEX non electric	II 2G Ex h IIC T6...T1 X Gb II 2D Ex h IIIC 85°C...530°C X Db		
Specific leakage rate shaft and body sealing	ISO FE-BH-CC3-SSA0-t(-40°C/+350°C)-PN40-ISO 15848-1		

\* Please consider the limitation of use of the positioner!

\*\* With DN15 with reduction of less than 25%, different leakage rates possible.  
Kvs-values see data sheet 8001.

### Fluid temperature

Rating	PN40	PN 16	PN 100	ANSI 150	ANSI 300	ANSI 600
Body material cpl. stainless steel						
Tmin [°C]	-60	-60	-60	-29	-29	-29
Tmax [°C]	530	530	530	530	530	530
Body material carbon steel with stainless steel body cover						
Tmin [°C]	-60	-60	-10	-20	-20	-10
Tmax [°C]	450	450	450	450	450	450

# High Temperature Sliding Gate Valve 8024

## Materials

Valve body	stainless steel 1.4408	carbon steel 1.0619
Head section	stainless steel 1.4404 or 316L	
Diaphragm casing	aluminium, KTL-coated	
Actuator springs	stainless steel 1.4310	
Packing	carbon-filled PTFE (1.4310)	
Valve stem	stainless steel 1.4571, roller burnished	
Fixed disc	stainless steel, stellite coated	STN2-disc
Sliding disc	special carbon material	SFC-disc (max. +300°C) STN2-disc

## Positioner

For technical information of our positioners please refer to the corresponding data sheets.

# High Temperature Sliding Gate Valve 8024-GS3

with integrated digital positioner, Type 8049

(also on-off valves and valves with other side-mounted positioner)



**Admissible differential pressures**  
(For temperatures of up to 120°C with PN-rating up to 38°C with ANSI-rating)

**For temperatures of 120°C (PN) or 38°C (ANSI) and above: obey application limits !**

**Disc pair: carbon - stainless steel coated**  
**SFC - stainless steel coated**

Actuator Size	125 cm <sup>2</sup>		250 cm <sup>2</sup>		500 cm <sup>2</sup>	
	4,5	5,5	3,0	4,0	3,0	4,5
DN	max. admissible differential pressure for PN 100-body (bar)					
15	100	100	100	100	-	-
20	100	100	100	100	-	-
25	88 (100)*	88 (100)*	88 (100)*	88 (100)*	-	-
32	88	100	100	100	-	-
40	67	83	88 (100)*	88 (100)*	-	-
50	44	54	75	91	100	100
65	37	45	63	76	80	80
80	23	29	40	48	48	48
100	15	16	25	31	33	33
125	10	11	17	21	23	23
150	7	8	13	15	16	16
200	4	5	7	9	15	16
250	2,7	3,4	4,6	5,6	9,5	10,5
Spring Configuration	Code 3 (Standard)	Code 4	Code 3 (Standard)	Code 4	Code 6 (Standard)	Code 8

Standard

\*: figures in brackets for bodys made of carbon steel

	Upper limits for admissible pressures in bar					
	PN16	PN40	PN100	ANSI150	ANSI 300	ANSI 600
P max. carbon steel	16	40	100	19,6	51,1	102,1
P max. stainless steel				19,0	49,6	99,3

**Disc pair: STN2**

Actuator Size	125 cm <sup>2</sup>		250 cm <sup>2</sup>		500 cm <sup>2</sup>	
	4,5	5,5	3,0	4,0	3,0	4,5
DN	max. admissible differential pressure for PN100-body (bar)					
15	100	100	100	100	-	-
20	81	100	100	100	-	-
25	60	75	88 (100)*	88 (100)*	88 (100)*	88 (100)*
32	45	56	77	93	100	100
40	31	38	53	64	72	72
50	18	22	31	38	64	77
65	15	18	26	31	53	62
80	9	10	15	19	32	36
100	5	6	9	11	19	23
125	3	4	6	7	13	16
150	2	3	4	5	9	11
200	2	2	3	3	6	7
Spring Configuration	Code 3 (Standard)	Code 4	Code 3 (Standard)	Code 4	Code 6 (Standard)	Code 8

Standard

\*:figures in brackets for bodys made of carbon steel

	Upper limits for admissible pressures in bar					
	PN16	PN40	PN100	ANSI150	ANSI 300	ANSI 600
P max. carbon steel	16	40	100	19,6	51,1	102,1
P max. stainless steel				19,0	49,6	99,3

# High Temperature Sliding Gate Valve 8024-GS3



with integrated p/p and i/p positioner, Type 8047

**Admissible differential pressures**  
(For temperatures of up to 120°C with PN-rating up to 38°C with ANSI-rating)

**For temperatures of 120°C (PN) or 38°C (ANSI) and above: obey application limits !**

**Disc pair: carbon - stainless steel coated**  
**SFC - stainless steel coated**

Actuator Size	125 cm <sup>2</sup>		250 cm <sup>2</sup>		500 cm <sup>2</sup>	
	1,5 up to 3,0	1,8 up to 3,8	1,2 up to 2,2	1,5 up to 2,7	1,2 up to 2,2	1,5 up to 2,7
Spring Range (bar)	1,5 up to 3,0	1,8 up to 3,8	1,2 up to 2,2	1,5 up to 2,7	1,2 up to 2,2	1,5 up to 2,7
Supply air (bar)	4	5	3	4	3	4,5
DN	max. admissible differential pressure for PN100-body (bar)					
15	100	100	100	100	-	-
20	77	96	100	100	-	-
25	57	71	88 (98)*	88 (100)*	88 (100)*	88 (100)*
32	42	52	73	88	100	100
40	29	36	49	60	88 (100)*	88 (100)*
50	17	21	29	35	60	72
65	14	17	24	29	49	59
80	8	10	14	17	29	35
100	5	6	9	10	18	22
125	3	4	6	7	12	14
150	2	3	4	5	9	10
200	2	2	3	3	5	6
250	0,9	1,1	1,5	1,9	3,2	3,8
Spring Configuration	Code 3 (Standard)	Code 4	Code 3 (Standard)	Code 4	Code 3 (Standard)	Code 4

Standard

\*: figures in brackets for bodys made of carbon steel

	Upper limits for admissible pressures in bar					
	PN16	PN40	PN100	ANSI150	ANSI 300	ANSI 600
P max. carbon steel	16	40	100	19,6	51,1	102,1
P max. stainless steel				19,0	49,6	99,3

**Disc pair: STN2**

Actuator Size	125 cm <sup>2</sup>		250 cm <sup>2</sup>		500 cm <sup>2</sup>	
	1,5 to 3,0	1,8 to 3,8	1,2 to 2,2	1,5 to 2,7	1,2 to 2,2	1,5 to 2,7
Spring Range (bar)	1,5 to 3,0	1,8 to 3,8	1,2 to 2,2	1,5 to 2,7	1,2 to 2,2	1,5 to 2,7
Supply air (bar)	4	5	3	4	3	4,5
DN	max. admissible differential pressure for PN100-body (bar)					
15	55	68	95	100	100	100
20	37	46	64	78	100	100
25	25	31	43	53	88 (89)*	88 (100)*
32	17	22	30	36	62	75
40	11	14	19	24	40	48
50	6	8	11	13	23	27
65	5	6	9	11	18	22
80	3	4	5	6	11	13
100	2	2	3	4	6	8
125	-	2	2	3	4	5
150	-	1	2	2	3	4
200	-	-	0,9	1,1	1,8	2,2
Spring Configuration	Code 3 (Standard)	Code 4	Code 3 (Standard)	Code 4	Code 6 (Standard)	Code 8

Standard

\*: figures in brackets for bodys made of carbon steel

	Upper limits for admissible pressures in bar					
	PN16	PN40	PN100	ANSI150	ANSI 300	ANSI 600
P max. carbon steel	16	40	100	19,6	51,1	102,1
P max. stainless steel				19,0	49,6	99,3

# High Temperature Sliding Gate Valve 8024-GS3



## Ordering Number System

1 2 3 4 5 6 7 8 9 10 11 12 13 14 15 16

8 0 2 4 / / / V R / / / M / / / Z / S

1 - 5 : Please quote all 5 sections.  
6 - 16: Quote only if required.

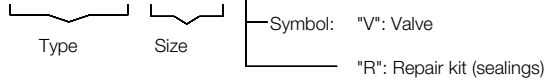

1. Valve type	2. Body design	3. Body material	4. Safety function	5. Actuator	6. Special version
R	High temperature sliding gate valve with pneumatic actuator (type 8024)	0 carbon steel 1.0619 1 stainless steel 1.4408	0 spring closes 1 spring opens	3 diaphragm actuator 125 cm <sup>2</sup> 4 diaphragm actuator 250 cm <sup>2</sup> 5 diaphragm actuator 500cm <sup>2</sup>	M to state if some sections 7 - 16 are quoted A nut and nut acc. DIN EN1092-1 C nut and tongue acc. DIN EN1092-1 E 2x lowered face acc. DIN EN1092-1 H lowered and raised face acc. DIN EN1092-1

7. Springs	8. Stem sealing	9. Moving disc	10. Fixed disc	11. Kvs-Values	12. Flow characteristic
- standard 4 8 springs 8 16 springs	- PTFE-packing self-adjusting (Standard) 1 additional bellow 1.4571 3 additional Inconel 625 bellow 2.4856	- carbon 9 STN2 S SFC	- stainless steel 1 1.4571, coated STN2 (only in combination with preceding section „9“ STN2)	- 100 % (stand.) A red. to 63 % 1 red. to 40 % B red. to 25 % 2 red. to 16 % C red. to 10 % 3 red. to 6,3 % 4 red. to 2,5 % 5 red. to 1% 6 red. to 20% 7 red. to 12% 8 red. to 2% 9 red. to 0,4 %	- linear 1 equal-%

13. Accessories	14. Positioners	15. Signalling equipment	16. Further versions
Z state, if in following sections accessories are quoted.	- without 1 p/p positioner Type 8047 3 i/p positioner Type 8047 6 i/p positioner Type 8047 Eex ib IIC T6 with plug conn. M12x1 8 i/p positioner with Type 8047 plug conn. M12x1 C digital positioner, Type 8049, 4 wire R digital positioner, Type 8049, 2 wire W digital positioner, Type 8049-ExPro, ATEX, IECEX K digital positioner type 8049 ExPro-FM with base plate in stainless steel; Ta = -10°C to +75°C; IS Class I Division 1, Groups A, B, C, D; T4 Entity; Class I Zone 0 AEx ia IIC T4 Entity, IP65 N digital positioner, Type 8049 IO-Link version Y „digital positioner type 8049 ExPro-FM with base plate in stainless steel; Ta = -10°C to +75°C; NI Class I Division 2, Groups A, B, C, D; T4 NIFW, IP65“	- without 0 2 limit switches M12x1 DC 10-30V PNP	S other special versions have to be quoted in letters

Ordering Example: 8024/050VRG103M-----Z3  
High temperature sliding gate valve type 8024 with pneumatic actuator, DN 50, PN 10 - PN 40, body material stainless steel, spring closes, actuator 125 cm<sup>2</sup>, PTFE-V-shaped sealings, function unit: carbon-stainless steel 1.4571 coated, linear characteristic, i/p-positioner

## Application limitations for GS3 valves in stainless steel

These pressure must not be exceeded for GS-valves from the GS3-series made of stainless steel, even though the actuator power might allow it.

Application limits for carbon steel bodys on request.

### PN40

DN	Sliding unit: carbon/SFC - stainless steel, coated							
	max. admissible pressures for GS3-valves in stainless steel							
	100°C	150°C	200°C	250°C	300°C	350°C	400°C	450°C
15	40	40	40	40	40	40	40	40
20	40	40	40	40	40	40	40	40
25	40	40	40	40	40	40	40	38
32	40	40	40	40	40	40	40	40
40	40	40	40	40	40	40	40	38
50	40	40	40	40	40	40	40	40
65	40	40	40	40	40	40	40	40
80	40	40	40	40	40	40	40	35
100	33	33	33	33	33	33	33	33
125	23	23	23	23	23	23	23	23
150	16	16	16	16	16	16	16	16
200 (only PN16)	16	16	15	13	12	11	10	9
250 (only PN16)	10	9	9	8	7	6	6	5

DN	Sliding unit: STN2									
	max. admissible pressures for GS3-valves in stainless steel									
	100°C	150°C	200°C	250°C	300°C	350°C	400°C	450°C	500°C	530°C
15	40	40	40	40	40	40	40	40	39	31
20	40	40	40	40	40	40	40	40	33	27
25	40	40	40	40	40	40	40	38	26	21
32	40	40	40	40	40	40	40	40	30	24
40	40	40	40	40	40	37	32	29	26	21
50	40	40	40	40	40	40	35	31	28	26
65	40	40	40	40	37	32	28	25	22	21
80	36	34	33	26	22	19	16	14	13	12
100	32	31	30	24	20	17	15	13	12	11
125	21	21	19	16	13	11	10	8	8	7
150	15	15	14	11	9	8	7	6	5	5
200 (only PN16)	8	7	6	5	4	3	3	2	2	2
250 (only PN16)	-	-	-	-	-	-	-	-	-	-

Limitation for SFC-sliding discs: 300°C

### PN100

DN	Sliding unit: carbon/SFC - stainless steel, coated							
	max. admissible pressures for GS3-valves in stainless steel							
	100°C	150°C	200°C	250°C	300°C	350°C	400°C	450°C
15	100	100	100	93	84	79	74	55
20	100	100	89	81	73	68	64	48
25	88	81	70	63	57	54	51	38
32	100	93	80	73	65	62	58	43
40	88	81	70	63	57	54	51	38
50	100	100	100	100	100	94	87	76
65	80	80	80	79	71	67	63	47
80	48	48	48	48	48	44	41	35

DN	Sliding unit: STN2									
	max. admissible pressures for GS3-valves in stainless steel									
	100°C	150°C	200°C	250°C	300°C	350°C	400°C	450°C	500°C	530°C
15	100	100	100	93	84	79	74	55	39	31
20	100	100	89	81	73	68	64	48	33	27
25	88	81	70	63	57	54	51	38	26	21
32	100	93	80	73	65	60	52	43	30	24
40	72	69	65	53	43	37	32	29	26	21
50	77	73	70	56	46	40	35	31	28	26
65	62	59	56	45	37	32	28	25	22	21
80	36	34	33	26	22	19	16	14	13	12

Limitation for SFC-sliding discs: 300°C

# High Temperature Sliding Gate Valve 8024-GS3



## ANSI150

DN	Sliding unit: carbon/SFC - stainless steel, coated									
	max. admissible pressures for GS3-valves in stainless steel									
	38°C	50°C	100°C	150°C	200°C	250°C	300°C	350°C	400°C	450°C
15-125	19,0	18,4	16,2	14,8	13,7	12,1	10,2	8,4	6,5	4,6
150	16,0	16,0	16,0	14,8	13,7	12,1	10,2	8,4	6,5	4,6
200	16,0	16,0	16,0	14,8	13,7	12,1	10,2	8,4	6,5	4,6
250	10,4	10,4	10,4	9,9	9,4	8,4	7,4	6,8	6,3	4,6

DN	Sliding unit: STN2											
	max. admissible pressures for GS3-valves in stainless steel											
	38°C	50°C	100°C	150°C	200°C	250°C	300°C	350°C	400°C	450°C	500°C	530°C
15-125	19,0	18,4	16,2	14,8	13,7	12,1	10,2	8,4	6,5	4,6	2,2	-
150	16,2	16,2	16,2	14,8	13,7	11,8	9,7	8,4	6,5	4,6	2,2	-
200	10,5	10,0	8,3	7,6	6,9	5,5	4,5	3,9	3,4	2,9	2,2	-
250	-	-	-	-	-	-	-	-	-	-	-	-

Limitation for SFC-sliding discs: 300°C

## ANSI300

DN	Sliding unit: carbon/SFC - stainless steel, coated									
	max. admissible pressures for GS3-valves in stainless steel									
	38°C	50°C	100°C	150°C	200°C	250°C	300°C	350°C	400°C	450°C
15-65	49,6	48,1	42,2	38,5	35,7	33,4	31,6	30,3	29,4	28,8
80	48,0	48,0	42,2	38,5	35,7	33,4	31,6	30,3	29,4	28,8
100	33,0	33,0	33,0	33,0	33,0	33,0	31,6	30,3	29,4	28,8
125	23,0	23,0	23,0	23,0	23,0	23,0	23,0	23,0	23,0	23,0
150	16,0	16,0	16,0	16,0	16,0	16,0	16,0	16,0	16,0	16,0
200	16,0	16,0	15,5	14,0	12,5	11,0	9,9	9,1	8,3	7,6

DN	Sliding unit: STN2											
	max. admissible pressures for GS3-valves in stainless steel											
	38°C	50°C	100°C	150°C	200°C	250°C	300°C	350°C	400°C	450°C	500°C	530°C
15	49,6	48,1	42,2	38,5	35,7	33,4	31,6	30,3	29,4	28,8	27,6	25,8
20	49,6	48,1	42,2	38,5	35,7	33,4	31,6	30,3	29,4	28,8	27,6	25,8
25	49,6	48,1	42,2	38,5	35,7	33,4	31,6	30,3	29,4	28,8	26,6	21,7
32	49,6	48,1	42,2	38,5	35,7	33,4	31,6	30,3	29,4	28,8	27,6	24,9
40	49,6	48,1	42,2	38,5	35,7	33,4	31,6	30,3	29,4	28,8	26,6	21,7
50	49,6	48,1	42,2	38,5	35,7	33,4	31,6	30,3	29,4	28,8	27,6	25,8
65	49,6	48,1	42,2	38,5	35,7	33,4	31,6	30,3	28,4	25,2	22,8	21,6
80	36,6	36,6	36,6	34,8	33,0	26,8	22,0	19,0	16,6	14,7	13,3	12,5
100	33,0	33,0	33,0	31,7	30,1	24,4	20,1	17,3	15,1	13,4	12,2	11,5
125	22,0	22,0	22,0	21,0	19,9	16,1	13,2	11,5	10,0	8,9	8,0	7,5
150	16,0	16,0	16,0	15,4	14,6	11,8	9,7	8,4	7,3	6,5	5,9	5,5
200	10,5	10,0	8,3	7,6	6,9	5,5	4,5	3,9	3,4	2,9	2,6	2,5

Limitation for SFC-sliding discs: 300°C

## ANSI600

DN	Sliding unit: carbon/SFC - stainless steel, coated									
	max. admissible pressures for GS3-valves in stainless steel									
	38°C	50°C	100°C	150°C	200°C	250°C	300°C	350°C	400°C	450°C
15	99,3	96,2	84,4	77,0	71,3	66,8	63,2	60,7	59,8	55,7
20	99,3	96,2	84,4	77,0	71,3	66,8	63,2	60,7	59,8	48,3
25	88,0	88,0	84,4	77,0	70,1	63,7	57,3	54,2	51,0	38,0
32	99,3	96,2	84,4	77,0	71,3	66,8	63,2	60,7	58,5	43,6
40	88,0	88,0	84,4	77,0	70,1	63,7	57,3	54,2	51,0	38,0
50	99,3	96,2	84,4	77,0	71,3	66,8	63,2	60,7	59,8	57,7
65	80,0	80,0	80,0	77,0	71,3	66,8	63,2	60,7	59,8	47,5
80	48,0	48,0	48,0	48,0	48,0	48,0	48,0	44,5	41,1	35,4

DN	Sliding unit: STN2											
	max. admissible pressures for GS3-valves in stainless steel											
	38°C	50°C	100°C	150°C	200°C	250°C	300°C	350°C	400°C	450°C	500°C	530°C
15	99,3	96,2	84,4	77,0	71,3	66,8	63,2	60,7	59,8	55,7	39,0	31,8
20	99,3	96,2	84,4	77,0	71,3	66,8	63,2	60,7	59,8	48,3	33,9	27,6
25	88,0	88,0	84,4	77,0	70,1	63,7	57,3	54,2	51,0	38,0	26,6	21,7
32	99,3	96,2	84,4	77,0	71,3	66,8	63,2	60,2	52,6	43,6	30,5	24,9
40	72,5	72,5	72,5	69,0	65,5	53,1	43,6	37,7	32,9	29,2	26,5	21,7
50	77,7	77,7	77,7	73,9	70,2	56,9	46,7	40,4	35,3	31,3	28,4	26,9
65	62,5	62,5	41,7	59,5	56,4	45,8	37,6	32,5	28,4	25,2	22,8	21,6
80	36,6	36,6	36,6	34,8	33,0	26,8	22,0	19,0	16,6	14,7	13,3	12,6

Limitation for SFC-sliding discs: 300°C

## Application limitations for GS3 valves in carbon steel

These pressure must not be exceeded for GS-valves from the GS3-series made of carbon steel, even though the actuator power might allow it.

### PN40

DN	Sliding unit: carbon/SFC - stainless steel, coated							
	max. admissible pressures for GS3-valves in carbon steel							
	100°C	150°C	200°C	250°C	300°C	350°C	400°C	450°C
15-32	40	40	40	40	40	40	40	40
40	40	40	40	40	40	40	40	40
50	40	40	40	40	40	40	40	40
65	40	40	40	40	40	40	40	40
80	40	40	40	40	40	40	40	38
100	33	33	33	33	33	33	33	33
125	23	23	23	23	23	23	23	23
150	16	16	16	16	16	16	16	16
200 (only PN16)	16	16	15	13	12	11	10	9
250 (only PN16)	10	9	9	8	7	6	6	5

DN	Sliding unit: STN2							
	max. admissible pressures for GS3-valves in carbon steel							
	100°C	150°C	200°C	250°C	300°C	350°C	400°C	450°C
15-32	40	40	40	40	40	40	40	40
40	40	40	40	40	40	40	32	29
50	40	40	40	40	40	40	35	31
65	40	40	40	40	37	32	28	25
80	36	34	33	26	22	19	16	14
100	33	31	30	24	20	17	15	13
125	22	21	19	16	13	11	10	8
150	16	15	14	11	9	8	7	6
200 (only PN16)	8	7	6	5	4	3	3	2
250 (only PN16)	-	-	-	-	-	-	-	-

Limitation for SFC-sliding discs: 300°C

### PN100

DN	Sliding unit: carbon/SFC - stainless steel, coated							
	max. admissible pressures for GS3-valves in carbon steel							
	100°C	150°C	200°C	250°C	300°C	350°C	400°C	450°C
15	100	100	100	100	100	100	93	71
20	100	100	100	100	100	100	100	80
25	100	100	100	100	94	87	81	62
32	100	100	100	100	100	99	93	72
40	100	100	100	100	94	87	81	63
50	100	100	100	100	100	94	87	81
65	80	80	80	80	80	76	70	65
80	48	48	48	48	48	44	41	38

DN	Sliding unit: STN2							
	max. admissible pressures for GS3-valves in carbon steel							
	100°C	150°C	200°C	250°C	300°C	350°C	400°C	450°C
15	100	100	100	100	100	100	93	71
20	100	100	100	100	100	100	100	80
25	100	100	100	100	94	87	79	62
32	100	100	100	84	69	60	52	46
40	72	69	65	53	43	37	32	29
50	77	73	70	56	46	40	35	31
65	62	59	56	45	37	32	28	25
80	36	34	33	26	22	19	16	14

Limitation for SFC-sliding discs: 300°C



# High Temperature Sliding Gate Valve 8024-GS3



## ANSI 150

DN	Sliding unit: carbon/SFC - stainless steel, coated									
	max. admissible pressures for GS3-valves in carbon steel									
	38°C	50°C	100°C	150°C	200°C	250°C	300°C	350°C	400°C	450°C
15-125	19,6	19,2	17,7	15,8	13,8	12,1	10,2	8,4	6,5	4,6
150	16,0	16,0	16,0	15,8	13,8	12,1	10,2	8,4	6,5	4,6
200	16,0	16,0	16,0	15,8	13,8	12,1	10,2	8,4	6,5	4,6
250	10,5	10,5	10,5	9,9	9,4	8,4	7,4	6,0	6,4	4,6

DN	Sliding unit: STN2									
	max. admissible pressures for GS3-valves in carbon steel									
	38°C	50°C	100°C	150°C	200°C	250°C	300°C	350°C	400°C	450°C
15-125	19,6	19,2	17,7	15,8	13,8	12,1	10,2	8,4	6,5	4,6
150	16,2	16,2	16,2	15,4	13,8	11,8	9,7	8,0	6,5	4,6
200	10,5	10,0	8,3	7,6	6,9	5,5	4,5	3,9	3,4	2,9
250	-	-	-	-	-	-	-	-	-	-

Limitation for SFC-sliding discs: 300°C

## ANSI 300

DN	Sliding unit: carbon/SFC - stainless steel, coated									
	max. admissible pressures for GS3-valves in carbon steel									
	38°C	50°C	100°C	150°C	200°C	250°C	300°C	350°C	400°C	450°C
15-25	51,1	50,1	46,6	45,1	43,8	41,9	39,8	37,6	34,7	23,0
32	51,1	50,1	46,6	45,1	43,8	41,9	39,8	37,6	34,7	23,0
40	51,1	50,1	46,6	45,1	43,8	41,9	39,8	37,6	34,7	23,0
50	51,1	50,1	46,6	45,1	43,8	41,9	39,8	37,6	34,7	23,0
65	51,1	50,1	46,6	45,1	43,8	41,9	39,8	37,6	34,7	23,0
80	48,0	48,0	46,6	45,1	43,8	41,9	39,8	37,6	34,7	23,0
100	33,0	33,0	33,0	33,0	33,0	33,0	33,0	37,6	33,0	23,0
125	23,0	23,0	23,0	23,0	23,0	23,0	23,0	23,0	23,0	23,0
150	16,0	16,0	16,0	16,0	16,0	16,0	16,0	16,0	16,0	16,0
200	16,0	16,0	16,0	14,8	13,7	12,1	10,2	8,4	8,3	7,6

DN	Sliding unit: STN2									
	max. admissible pressures for GS3-valves in carbon steel									
	38°C	50°C	100°C	150°C	200°C	250°C	300°C	350°C	400°C	450°C
15-25	51,1	50,1	46,6	45,1	43,8	41,9	39,8	37,6	34,7	23,0
32	51,1	50,1	46,6	45,1	43,8	41,9	39,8	37,6	34,7	23,0
40	51,1	50,1	46,6	45,1	43,8	41,9	39,8	37,6	32,9	23,0
50	51,1	50,1	46,6	45,1	43,8	41,9	39,8	37,6	34,7	23,0
65	41,7	41,7	41,7	39,7	37,6	33,5	37,6	32,5	28,4	23,0
80	36,6	36,6	36,6	34,8	33,0	26,8	22,0	19,0	16,6	14,7
100	33,0	33,0	33,0	31,7	30,1	24,4	20,0	17,0	15,1	13,4
125	22,1	22,1	22,1	21,0	19,9	16,1	13,2	11,0	10,0	8,9
150	16,0	16,0	16,0	15,4	14,6	11,8	9,7	8,0	7,3	6,5
200	10,5	10,0	8,3	7,6	6,9	5,5	4,5	3,9	3,4	2,9

Limitation for SFC-sliding discs: 300°C

## ANSI 600

DN	Sliding unit: carbon/SFC - stainless steel, coated									
	max. admissible pressures for GS3-valves in carbon steel									
	38°C	50°C	100°C	150°C	200°C	250°C	300°C	350°C	400°C	450°C
15-25	102,1	100,2	93,2	90,2	87,6	83,9	79,6	75,1	69,4	46,0
32	102,1	100,2	93,2	90,2	87,6	83,9	79,6	75,1	69,4	46,0
40	100,0	100,0	93,2	90,2	87,6	83,9	79,6	75,1	69,4	46,0
50	100,0	100,0	93,2	90,2	87,6	83,9	79,6	75,1	69,4	46,0
65	80,0	80,0	80,0	80,0	80,0	80,0	79,6	75,1	69,4	46,0
80	48,0	48,0	48,0	48,0	48,0	48,0	48,0	44,0	41,1	38,3

DN	Sliding unit: STN2									
	max. admissible pressures for GS3-valves in carbon steel									
	38°C	50°C	100°C	150°C	200°C	250°C	300°C	350°C	400°C	450°C
15-25	102,1	100,2	93,2	90,2	87,6	83,9	79,6	75,1	69,4	46,0
32	102,1	100,2	93,2	90,2	87,6	83,9	69,6	60,0	52,6	46,0
40	72,5	72,5	72,5	69,0	65,5	53,1	43,6	37,0	32,9	29,2
50	77,7	77,7	77,7	73,9	70,2	56,9	46,7	40,0	35,3	31,3
65	62,5	62,5	62,5	59,5	56,4	45,8	37,6	32,0	28,4	25,2
80	36,6	36,6	36,6	36,8	33,0	26,8	22,0	19,0	16,6	14,7

Limitation for SFC-sliding discs: 300°C

# High Temperature Sliding Gate Valve 8024-GS3

with integrated digital positioner, Type 8049

## Dimensions and Weights

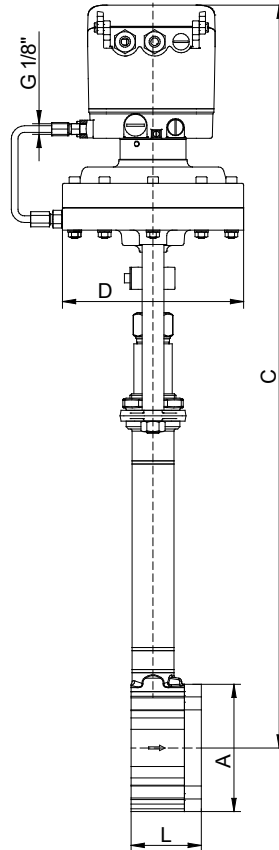

digitaler - positioner Type 8049

DN	Ø A	C *	Ø D for actuator			L	Stroke	Weight (kg) for actuator		
			D 125	D250	D500			D 125	D 250	D 500
15	64	655	165	222	222	56	6	8,5	10,7	14,4
20	72	660	165	222	222	56	6	8,7	10,9	14,6
25	82	665	165	222	222	56	6	9,1	11,3	15,0
32	89	670	165	222	222	56	6	9,5	11,7	15,4
40	99	675	165	222	222	56	6	9,9	12,1	15,8
50	116	685	165	222	222	64	8	11,5	13,7	17,4
65	138	695	165	222	222	68	8	13,3	15,5	19,2
80	153	705	165	222	222	70	8	14,4	16,6	20,3
100	184	715	165	222	222	75	8,5	17,9	20,1	23,8
125	212	730	165	222	222	80	8,5	22,1	24,3	28,0
150	242	745	165	222	222	80	8,5	25,8	28,0	31,7
200	302	775	165	222	222	93	8,5	42,7	44,9	48,6
250	360	800	165	222	222	96	8,5	47,9	50,1	53,8

\* for actuator D500 +47,5mm

Dimensions in mm

# High Temperature Sliding Gate Valve 8024-GS3

with integrated i/p and p/p positioner, Type 8047

## Dimensions and Weights

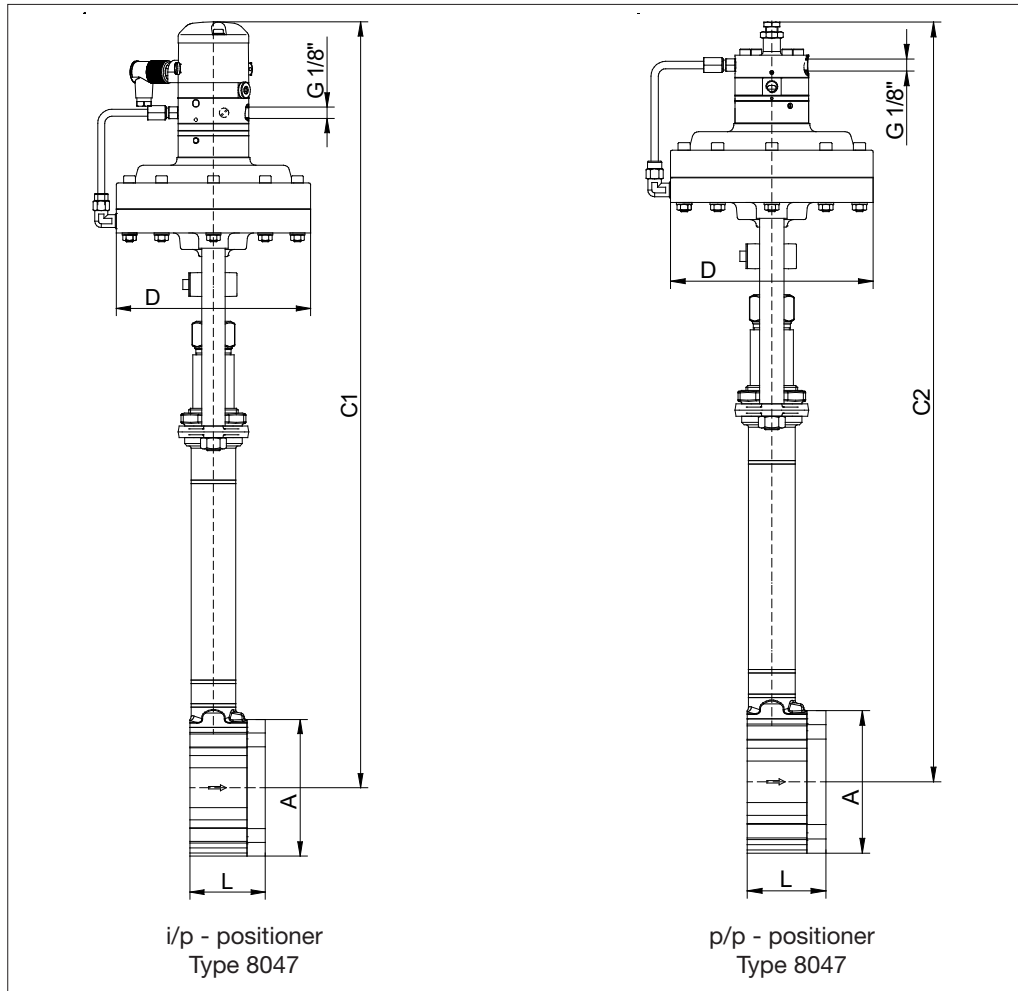

DN	Ø A	C1 *	C2 *	Ø D for actuator			L	Stroke	Weight (kg) for actuator		
				D 125	D250	D500			D 125	D 250	D 500
15	64	625	590	165	222	222	56	6	8,5	10,7	14,4
20	72	630	595	165	222	222	56	6	8,7	10,9	14,6
25	82	635	600	165	222	222	56	6	9,1	11,3	15,0
32	89	640	605	165	222	222	56	6	9,5	11,7	15,4
40	99	645	610	165	222	222	56	6	9,9	12,1	15,8
50	116	655	620	165	222	222	64	8	11,5	13,7	17,4
65	138	665	630	165	222	222	68	8	13,3	15,5	19,2
80	153	675	640	165	222	222	70	8	14,4	16,6	20,3
100	184	685	650	165	222	222	75	8,5	17,9	20,1	23,8
125	212	700	665	165	222	222	80	8,5	22,1	24,3	28,0
150	242	715	680	165	222	222	80	8,5	25,8	28,0	31,7
200	302	745	710	165	222	222	93	8,5	42,7	44,9	48,6
250	360	770	735	165	222	222	96	8,5	47,9	50,1	53,8

\* for actuator D500 +47,5mm

Dimensions in mm