

Flanged Valve 7032

1/2" up to 6"; 580 psi and 230 psi

Pneumatically operated flanged valves for the control of neutral, lightly and highly aggressive fluids.

- Compact design
- Unaffected by lightly contaminated media
- For temperatures from -100°C up to +220°C
- Working pressures up to 40 bars
- Rotatable actuator
- Customized execution



Technical Information

Nominal sizes	1/2" up to 3"	4" up to 6"
Body material	1.4408 (CF8M)	1.4308 (CF8)
Connection	Flanges acc. ASME 16.5 ANSI Cl. 150 (1/2"-3") Flanges acc. DIN EN 1092-1 (1/2"-2")	Flanges acc. DIN EN 1092-1
Dimensions	Acc. ANSI/ISA-75.08.01 (1/2"-3") Acc. DIN EN 558-1 Row 1 (1/2"-2")	acc. DIN EN 558-1 Row 1
Nominal pressure	ANSI150 or PN40	PN 16
Max. fluid temperature*: with metal bonnet with plastic bonnet diaphragm act. stainless steel	-22°F up to +338°F, -148°F up to +428°F -22°F up to +275°F -22°F bis +392°F, opt. -22°F bis +428°F	-22°F up to +338°F, -22°F up to +392°F -22°F up to +275°F -22°F up to +392°F
Ambient temperature*	-22°F up to +140°F (special versions from -40°F up to +212°F possible)	
Viscosity of media	maximum 600cSt, 80°E (600 mm ² /s)	
Vakuum	maximum 0,001 bar abs	
Working pressure	See tables and diagramms, limitation for dangerous gases acc. Pressure equipment directive 2014/68/EU (category I): PS (psi) x DN (inch) / 1.75 ≤ 1000 and DN (inch) * 25,4 ≤ 100 limitation for dangerous liquids acc. Pressure equipment directive 2014/68/EU (category I): PS (psi) x DN (inch) / 1.75 < 2000	
Working pressure for packing underneath	maximum 175 psi	
Working pressure for bellows	maximum 230 psi	
Classification DIN EN ISO15848-1	ISO FE BH-CC3-SSA1-t(-22°F, +176°F) Test pressure 580 psi	
Leakage acc. EN 12266-1	leakage class A	

*: For further temperature versions and limits please consult the table on page 15

Options and accessories

- Stroke limitation
- Manual emergency operation
- El. position indicator with inductive or mechanical limit switches
- Pilot valves
- AS-I control head
- Oil- and greasefree version, PTFE-free version, siliconfree version
- Version for oxygen or ozon applications
- FDA-compliant version
- Version acc. regular (EG) 1935/2004
- Offshore-version
- Feedback unit for inductive limit switches
- Version for higher pilot pressures
- Version for under water use
- ...

Build up function

Spring closes

The function „spring closes“ may be applied closing against or closing with the flow. In the configuration closing with the flow the valve should only be used for gaseous fluids. If used for liquids, water hammers may occur.

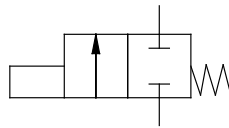

Removable position indicator

Bonnet can be rotated as required (compressed air connection)

Direct pressure control (with a pilot valve if required)

Head section

Piston rod stainless steel

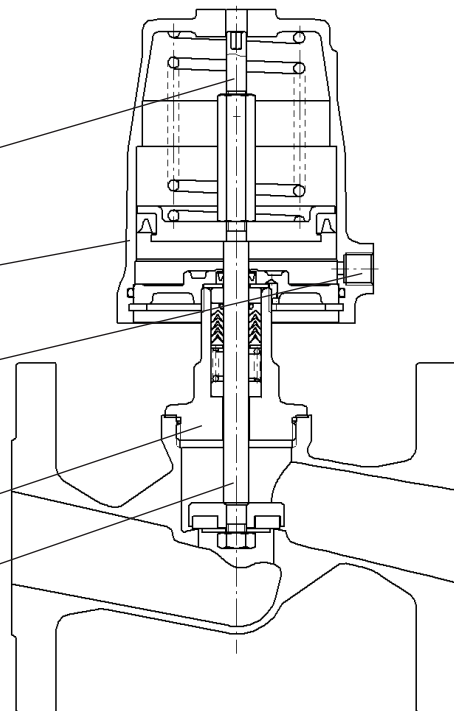

Spring opens

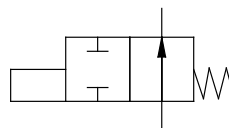

Bonnet material chrome plated brass, plastiv, stainless steel or Aluminium

Exterior lip seal

Leak detector

PTFE packing, special version free (or packing underneath)

Seating seal in PTFE or other materials

Body

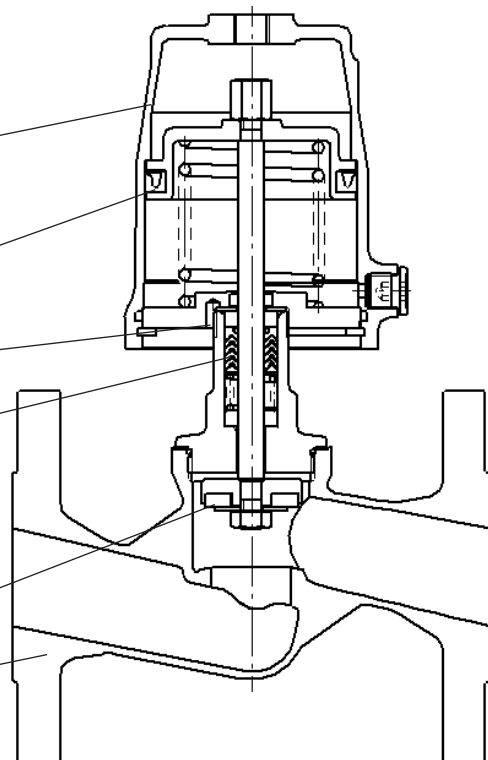

Pilot- and differential pressures

Spring closes (closing against flow)

Nominal size	Version	Actuator	Springs	Max. differential pressure [psi]			Pilot pressure [psi]
				PTFE	PEEK 7	PEEK 8	
1/2"	Standard	2"	1	220	-	155	51 - 145
			2	395	71	330	66 - 145
			3	580	245	510	83 - 145
		3"	1	580	580	580	51 - 145
3/4"	Standard	2"	1	73	-	26	51 - 145
			2	150	-	105	66 - 145
			3	230	-	185	83 - 145
		3"	1	555	315	505	51 - 145
			2	580	510	580	64 - 145
			3	580	580	580	82 - 145
1"	Standard	2"	1	33	-	-	51 - 145
			2	81	-	44	66 - 145
			3	125	-	92	83 - 145
		3"	1	295	120	260	51 - 145
			2	405	220	365	64 - 145
			3	525	345	490	82 - 145
		5"	1	260	84	220	19 - 145
			2	565	380	525	32 - 145
			3	580	580	580	45 - 145
1 1/4"	Standard	2"	1	14	-	-	51 - 145
			2	44	-	15	66 - 145
			3	73	-	44	83 - 145
		3"	1	165	26	140	51 - 145
			2	230	91	200	64 - 145
			3	300	155	275	82 - 145
		5"	1	145	8	120	19 - 145
			2	325	185	295	32 - 145
			3	460	315	435	45 - 145
			4	520	380	490	58 - 145
10"	8	580	535	580	40 - 87		
1 1/2"	Standard	2"	2	27	-	-	66 - 145
			3	49	-	24	83 - 145
			1	98	-	73	51 - 145
		3"	2	135	20	115	64 - 145
			3	180	62	150	82 - 145
			1	91	-	68	19 - 145
	d16	5"	2	170	88	180	32 - 145
			3	290	165	260	45 - 145
			4	300	185	280	58 - 145
		10"	8	445	330	425	40 - 87
			12	580	505	580	54 - 87

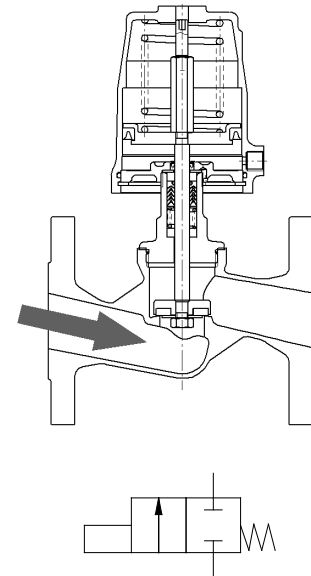

= Standard spring configuration

d16: reinforced design with 16mm (0.63") piston rod

PEEK 7: Seating seal made of PEEK for use below 320°F

PEEK 8: Seating seal made of PEEK for use above 320°F

For soft seals such as EPDM, FKM, NBR or Vulkolan the same values as with PTFE are valid

Pilot- and differential pressures

Spring closes (closing against flow)

Nominal size Seating seal	Version	Actuator	Springs	Max. differential pressure pressure [psi]			Pilot pressure [psi]
				PTFE	PEEK 7	PEEK 8	
2"	Standard	2"	2	13	-	-	66 - 145
			3	26	-	7	83 - 145
		3"	1	58	-	39	51 - 145
			2	85	-	65	64 - 145
		5"	3	110	15	92	82 - 145
			1	53	-	34	19 - 145
	d16	5"	2	125	33	110	34 - 0
			3	180	85	155	45 - 145
		10"	4	185	95	165	58 - 145
			8	280	185	265	40 - 87
		12	395	300	375	54 - 87	
2 1/2"	Standard (d16)	3"	2	43	-	29	64 - 145
			3	59	-	44	82 - 145
		5"	1	27	-	13	19 - 145
			2	69	-	56	32 - 145
			3	100	29	87	45 - 145
			4	105	36	94	58 - 145
		10"	8	155	87	145	40 - 87
			12	215	145	200	54 - 87
	pressure balanced	3"	2	200	-	140	64 - 145
			2	325	-	260	32 - 145
			3	360	135	360	45 - 145
	3"	Standard (d16)	3"	2	29	-	15
3				39	-	27	82 - 145
5"			1	17	-	-	19 - 145
			2	46	-	34	32 - 145
			3	68	8	56	47 - 145
			4	72	13	60	58 - 145
10"			8	105	49	97	40 - 87
			12	150	92	140	54 - 87
pressure balanced		3"	2	290	-	260	67 - 145
			3	290	-	290	82 - 145
		5"	2	290	-	290	32 - 145
			3	290	130	290	47 - 145

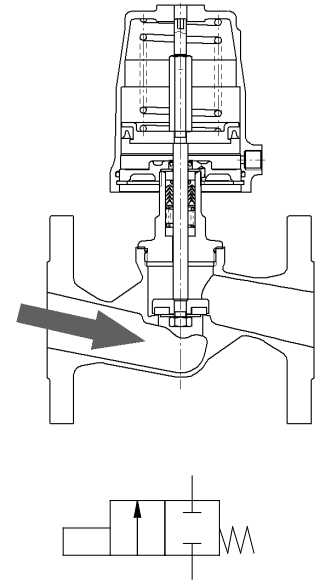

= Standard spring configuration

d16: reinforced design with 16mm (0.63") piston rod

PEEK 7: Seating seal made of PEEK for use below 320°F

PEEK 8: Seating seal made of PEEK for use above 320°F

For soft seals such as EPDM, FKM, NBR or Vulkolan the same values as with PTFE are valid

Pilot- and differential pressures

Spring closes (closing against flow)

Nominal size Seating seal	Version	Actuator	Springs	Max. differential pressure pressure [psi]			Pilot pressure [psi]
				PTFE	PEEK 7	PEEK 8	
4"	Standard (d16)	5"	1	5	-	-	18 - 145
			2	20	-	11	33 - 145
			3	30	-	23	46 - 145
			4	33	-	24	58 - 145
		10"	8	53	10	44	39 - 87
			12	76	33	68	53 - 87
	pressure balanced	3"	1	230	-	230	60 - 145
			2	230	-	230	66 - 145
			3	230	-	230	84 - 145
		5"	1	230	-	230	24 - 145
			2	230	-	230	33 - 145
			3	230	-	230	46 - 145
			4	230	-	230	58 - 145
		10"	8	230	230	230	39 - 87
			12	230	230	230	53 - 87
5"	Standard (d16)	5"	1	1	-	-	18 - 145
			2	11	-	4	33 - 145
			3	18	-	11	46 - 145
			4	18	-	13	58 - 145
		10"	8	33	-	26	39 - 87
			12	47	13	40	53 - 87
	pressure balanced	3"	1	230	-	-	76 - 145
			2	230	-	230	78 - 145
			3	230	-	230	84 - 145
		5"	1	230	-	-	30 - 145
			2	230	-	230	33 - 145
			3	230	-	230	46 - 145
			4	230	-	230	58 - 145
		10"	8	230	-	230	39 - 87
			12	230	16	230	53 - 87
6"	Standard (d16)	5"	1	-	-	-	
			2	7	-	1	33 - 145
			3	11	-	5	46 - 145
			4	11	-	5	58 - 145
		10"	8	21	-	15	39 - 87
			12	31	2	26	53 - 87
	pressure balanced	5"	1	230	-	-	42 - 145
			2	230	-	230	43 - 145
			3	230	-	230	46 - 145
			4	230	-	230	58 - 145
		10"	8	230	-	230	39 - 87
			12	230	230	230	53 - 87

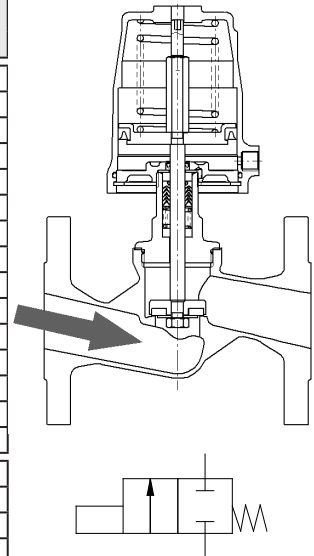

= Standard spring configuration

d16: reinforced design with 16mm (0.63") piston rod

PEEK 7: Seating seal made of PEEK for use below 320°F

PEEK 8: Seating seal made of PEEK for use above 320°F

For soft seals such as EPDM, FKM, NBR or Vulkolan the same values as with PTFE are valid

Pilot- and differential pressures

Function „spring opens“, closing against flow

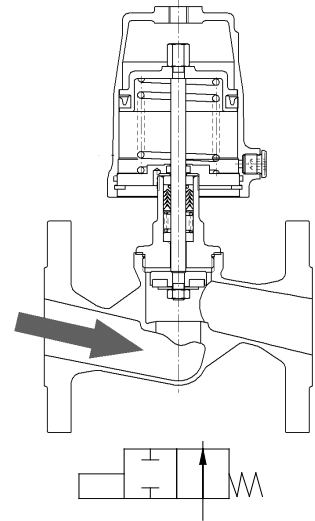

Seating seal PTFE, EPDM, FKM, NBR or Vulkolan

Nominal size	Version	Actuator ϕ	Max. differential pressure [psi] at available pilot pressure [psi]												
			20	30	40	50	60	70	80	90	100	110	120	130	140
1/2"	Standard	2"	0	0	0	135	275	415	555	580	-	-	-	-	-
		3"	265	580	580	-	-	-	-	-	-	-	-	-	-
3/4"	Standard	2"	0	0	0	39	105	175	245	315	385	455	520	580	580
		3"	100	285	465	580	-	-	-	-	-	-	-	-	-
1"	Standard	2"	0	0	0	14	55	97	135	175	220	260	300	340	385
		3"	45	150	260	370	475	580	580	-	-	-	-	-	-
1 1/4"	Standard	2"	0	0	0	2	28	54	79	105	130	155	180	205	230
		3"	17	84	150	215	285	350	420	485	555	580	-	-	-
		5"	200	365	530	580	-	-	-	-	-	-	-	-	-
1 1/2"	Standard	2"	0	0	0	0	16	34	52	70	88	105	120	140	155
		3"	2	49	96	140	190	235	280	330	375	425	470	515	565
		5"	130	245	360	475	580	-	-	-	-	-	-	-	-
2"	Standard	2"	0	0	0	0	6	18	29	41	52	64	75	87	98
		3"	0	27	57	88	115	145	175	205	235	265	300	330	360
		5"	80	155	225	300	360	-	-	-	-	-	-	-	-
2 1/2"	Standard (d16)	3"	0	9	26	43	59	76	93	110	125	140	160	175	190
		5"	41	83	125	165	205	250	290	330	360	-	-	-	-
3"	Standard (d16)	3"	0	4	16	28	39	51	63	74	86	97	105	120	130
		5"	26	56	85	110	140	170	200	230	260	285	-	-	-
4"	Standard	3"	0	0	5	11	17	24	30	36	42	48	54	60	66
		5"	11	26	41	56	72	87	100	115	130	145	160	175	190
		10"	0	31	62	94	125	155	185	-	-	-	-	-	-
5"	Standard	3"	0	0	2	6	10	14	17	21	25	29	33	37	41
		5"	5	15	25	35	44	54	64	74	83	93	100	110	120
		10"	0	18	38	59	79	99	115	-	-	-	-	-	-
6"	Standard	5"	3	9	16	23	30	37	43	50	57	64	70	77	84
		10"	0	12	26	40	54	68	82	-	-	-	-	-	-

d16: reinforced design with 16mm (0.63") piston rod
 Actuator 2": max. pilot pressure 15 psi above the required pilot pressure
 Actuator 3": max. pilot pressure 12 psi above the required pilot pressure
 Actuator 5" and 10": max. pilot pressure 7 psi above the required pilot pressure

Pilot- and differential pressures

Function „spring opens“, closing against flow

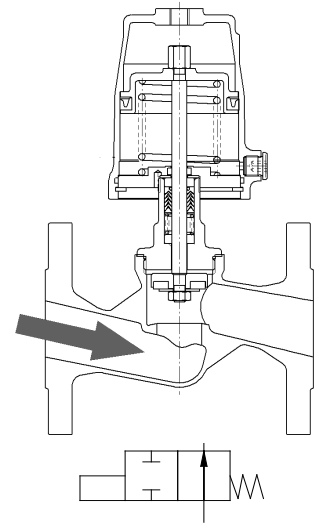

Seating seal PEEK-8

Nominal size	Version	Actuator	Max. differential pressure [psi] at available pilot pressure [psi]													
			20	30	40	50	60	70	80	90	100	110	120	130	140	
1/2"	Standard	2"	0	0	0	71	210	350	490	580	580	-	-	-	-	
		3"	200	565	580	-	-	-	-	-	-	-	-	-	-	
3/4"	Standard	2"	0	0	0	0	61	130	200	265	335	405	475	545	580	
		3"	56	235	420	580	580	-	-	-	-	-	-	-	-	
1"	Standard	2"	0	0	0	0	19	60	100	140	180	225	265	305	350	
		3"	8	115	225	330	440	550	580	-	-	-	-	-	-	
1 1/4"	Standard	2"	0	0	0	0	0	25	51	76	100	125	150	175	205	
		3"	0	56	120	190	255	325	390	455	525	580	-	-	-	
		5"	170	335	505	580	-	-	-	-	-	-	-	-	-	
1 1/2"	Standard	3"	0	25	72	115	165	210	260	305	350	400	445	495	540	
		5"	105	220	335	455	570	-	-	-	-	-	-	-	-	
2"	Standard	3"	0	8	38	69	99	125	155	190	220	250	280	310	340	
		5"	61	135	210	285	360	-	-	-	-	-	-	-	-	
2 1/2"	Standard (d16)	3"	0	0	12	28	45	62	78	95	110	125	145	160	175	
		5"	27	69	110	150	190	235	275	320	360	-	-	-	-	
		10"	0	81	165	255	340	-	-	-	-	-	-	-	-	
3"	Standard (d16)	3"	0	0	4	16	27	39	51	62	74	86	97	105	120	
		5"	14	44	73	100	130	160	185	215	245	275	290	-	-	
		10"	0	52	110	170	230	290	-	-	-	-	-	-	-	
4"	Standard	3"	0	0	0	3	9	15	21	27	33	39	45	51	57	
		5"	2	17	33	48	63	78	93	105	120	135	150	165	180	
		10"	0	22	54	85	115	145	180	-	-	-	-	-	-	
5"	Standard	5"	0	8	18	28	37	47	57	67	76	86	96	105	115	
		10"	0	11	32	52	72	92	110	-	-	-	-	-	-	
6"	Standard	5"	0	4	10	17	24	31	38	44	51	58	65	71	78	
		10"	0	6	20	34	48	62	76	-	-	-	-	-	-	

d16: reinforced design with 16mm (0.63") piston rod
 PEEK 7: Seating seal made of PEEK for use below 320°F
 PEEK 8: Seating seal made of PEEK for use above 320°F
 Actuator 2": max. pilot pressure 15 psi above the required pilot pressure
 Actuator 3": max. pilot pressure 12 psi above the required pilot pressure
 Actuator 5" and 10": max. pilot pressure 7 psi above the required pilot pressure

Flanged Valve 7032

Pilot- and differential pressures

Function „spring opens“, closing against flow

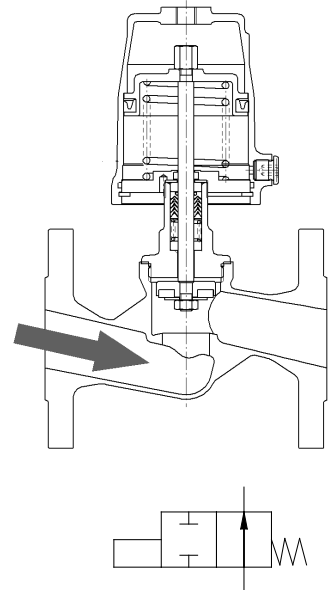

Seating seal PEEK-7

Nominal size	Version	Actuator	Max. differential pressure [psi] at available pilot pressure [psi]												
			20	30	40	50	60	70	80	90	100	110	120	130	140
1/2"	Standard	2"	0	0	0	0	0	85	225	365	505	580	-	-	-
		3"	0	300	580	-	-	-	-	-	-	-	-	-	-
3/4"	Standard	2"	0	0	0	0	0	0	13	82	150	220	290	360	425
		3"	0	51	230	415	580	580	-	-	-	-	-	-	-
1"	Standard	3"	0	0	81	185	295	405	515	580	-	-	-	-	-
		5"	160	425	580	-	-	-	-	-	-	-	-	-	-
1 1/4"	Standard	3"	0	0	9	76	140	210	275	345	410	480	545	580	-
		5"	59	225	390	555	-	-	-	-	-	-	-	-	-
1 1/2"	Standard	3"	0	0	0	24	71	115	165	210	255	305	350	400	445
		5"	12	125	240	360	475	580	-	-	-	-	-	-	-
2"	Standard	3"	0	0	0	0	23	53	83	110	140	170	200	235	265
		5"	0	59	130	205	280	355	-	-	-	-	-	-	-
		10"	0	80	230	360	-	-	-	-	-	-	-	-	-
2 1/2"	Standard (d16)	5"	0	11	53	95	135	175	220	260	300	345	360	-	-
		10"	0	24	110	195	280	360	-	-	-	-	-	-	-
3"	Standard (d16)	5"	0	0	25	54	83	110	140	170	200	225	255	285	-
		10"	0	5	65	125	185	245	290	-	-	-	-	-	-
4"	Standard	5"	0	0	0	13	28	44	59	74	89	100	115	135	150
		10"	0	0	19	51	82	110	145	-	-	-	-	-	-
5"	Standard	5"	0	0	0	0	10	19	29	39	49	58	68	78	88
		10"	0	0	4	24	44	64	85	-	-	-	-	-	-
6"	Standard	5"	0	0	0	0	1	8	14	21	28	35	42	48	55
		10"	0	0	0	11	25	39	53	-	-	-	-	-	-

d16: reinforced design with 16mm (0.63") piston rod

PEEK 7: Seating seal made of PEEK for use below 320°F

PEEK 8: Seating seal made of PEEK for use above 320°F

Actuator 2": max. pilot pressure 15 psi above the required pilot pressure

Actuator 3": max. pilot pressure 12 psi above the required pilot pressure

Actuator 5" and 10": max. pilot pressure 7 psi above the required pilot pressure

Pilot- and differential pressures

Function „spring closes“, closing with flow

- Seat valve closing with the flow, spring closes
- Use preferably for gaseous fluids
- With liquids, waterhammers are possible

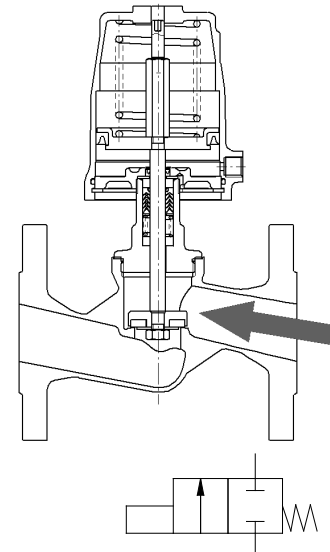

Seating seal PTFE, EPDM, FKM, NBR or Vulkolan

Nominal Size	Version	Actuator	Springs	Max. differential pressure [psi] at available pilot pressure [psi]													
				20	30	40	50	60	70	80	90	100	110	120	130	140	
1/2"	Standard	2"	Standard	0	0	315	580	580	580	580	580	580	580	580	580	580	580
3/4"	Standard	2"	Standard	0	16	110	210	305	405	500	580	580	580	580	580	580	580
		3"	Standard	155	410	580	580	580	580	580	580	580	580	580	580	580	580
1"	Standard	2"	Standard	0	9	59	105	155	205	255	305	355	405	455	475	475	
		3"	Standard	86	215	345	475	475	475	475	475	475	475	475	475	475	475
1 1/4"	Standard	2"	Standard	0	5	34	62	91	120	145	175	205	230	260	275	275	
		3"	Standard	52	125	200	275	350	425	500	505	505	505	505	505	505	
		5"	Standard	255	440	505	505	505	505	505	505	505	505	505	505	505	
1 1/2"	Standard	2"	Standard	0	0	13	32	52	71	90	110	125	145	165	185	185	
		3"	Standard	2	53	100	155	205	255	305	330	330	330	330	330	330	
		5"	Standard	80	205	330	330	330	330	330	330	330	330	330	330	330	
		d16	Standard	78	200	325	450	570	580	580	580	580	580	580	580	580	
2"	Standard	2"	Standard	0	0	9	21	33	45	57	69	81	93	105	115	115	
		3"	Standard	2	34	65	97	125	160	190	215	215	215	215	215	215	
		5"	Standard	51	125	205	215	215	215	215	215	215	215	215	215	215	
		d16	Standard	49	125	200	280	360	435	515	550	550	550	550	550	550	
2 1/2"	Standard (d16)	3"	Standard	0	15	32	49	66	84	100	115	135	150	170	185	200	
		5"	Standard	26	69	110	155	195	240	280	325	360	360	360	360	360	
3"	Standard (d16)	3"	Standard	0	10	22	34	46	58	70	81	93	105	115	125	140	
		5"	Standard	18	48	77	105	135	165	195	225	255	285	290	290	290	
		10"	Standard	15	77	135	200	260	290	290	-	-	-	-	-		
4"	Standard (d16)	3"	1	0	0	3	9	15	22	28	34	40	46	52	58	65	
		5"	Standard	10	25	40	56	71	86	100	115	130	145	160	175	190	
		10"	6	8	39	71	100	135	165	195	-	-	-	-	-		
5"	Standard (d16)	3"	1	0	0	2	6	10	14	18	21	25	29	33	37	41	
		5"	Standard	6	16	26	35	45	55	65	75	84	94	100	110	120	
		10"	6	5	25	45	66	86	105	125	-	-	-	-	-		
6"	Standard (d16)	3"	1	0	0	1	4	7	9	12	15	17	20	23	26	28	
		5"	Standard	4	11	18	24	31	38	45	52	58	65	72	79	86	
		10"	6	3	17	31	45	60	74	88	-	-	-	-	-		

d16: reinforced design with 16mm (0.63") piston rod

Flanged Valve 7032

Pilot- and differential pressures

Function „spring closes“, closing with flow

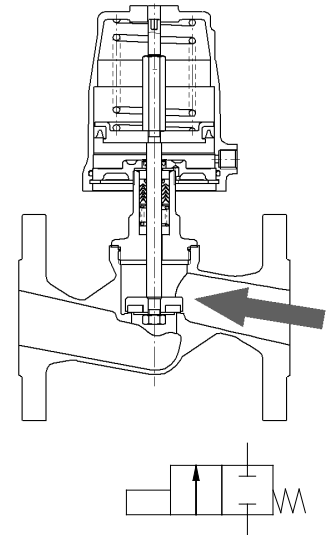

Seating seal PEEK-8

Nominal Size	Version	Actuator	Springs	Max. differential pressure [psi] at available pilot pressure [psi]													
				20	30	40	50	60	70	80	90	100	110	120	130	140	
1/2"	Standard	2"	2	0	0	0	32	365	580	580	580	580	580	580	580	580	
3/4"	Standard	2"	2	0	0	0	54	150	245	345	440	540	580	580	580	580	
		3"	1	0	0	0	245	500	580	580	580	580	580	580	580	580	
		5"	1	290	580	580	580	580	580	580	580	580	580	580	580	580	
1"	Standard	2"	2	0	0	0	29	79	125	175	225	275	325	375	425	475	
		3"	1	0	0	22	150	280	415	475	475	475	475	475	475	475	
		5"	1	165	475	475	475	475	475	475	475	475	475	475	475	475	
1 1/4"	Standard	2"	2	0	0	0	17	45	74	100	130	160	185	215	245	275	
		3"	1	0	0	26	100	175	250	325	400	475	505	505	505	505	
		5"	1	100	285	475	505	505	505	505	505	505	505	505	505	505	
1 1/2"	Standard	3"	1	0	0	34	85	135	185	235	285	330	330	330	330	330	
		5"	2	0	79	205	330	330	330	330	330	330	330	330	330	330	
	d16	5"	2	0	76	200	320	445	570	580	580	580	580	580	580	580	
2"	Standard	3"	2	0	0	0	26	58	90	120	150	185	215	215	215	215	
		5"	2	0	51	125	205	215	215	215	215	215	215	215	215		
		5"	2	0	48	125	200	280	355	435	510	550	550	550	550		
	d16	10"	6	41	200	360	520	550	550	550	-	-	-	-	-		
2 1/2"	d16	5"	2	0	25	68	110	150	195	240	280	325	360	360	360	360	
		10"	6	23	110	200	290	360	360	360	-	-	-	-	-		
3"	d16	5"	2	0	17	47	77	105	135	165	195	225	255	285	290	290	
		10"	6	15	77	135	200	260	290	290	-	-	-	-	-		
4"	Standard (d16)	3"	2	0	0	0	4	10	16	22	28	35	41	47	53	59	
		5"	2	0	10	25	40	56	71	86	100	115	130	145	160	175	
		10"	6	8	39	71	100	135	165	195	-	-	-	-	-		
5"	Standard (d16)	3"	3	0	0	0	2	6	10	14	18	22	26	30	34	38	
		5"	2	0	6	16	26	35	45	55	65	75	84	94	100	110	
		10"	6	5	25	45	66	86	105	125	-	-	-	-	-		
6"	Standard (d16)	5"	2	0	4	11	18	24	31	38	45	52	58	65	72	79	
		10"	6	3	17	31	45	60	74	88	-	-	-	-	-		

d16: reinforced design with 16mm (0.63") piston rod
 PEEK 7: Seating seal made of PEEK for use below 320°F
 PEEK 8: Seating seal made of PEEK for use above 320°F

Flanged Valve 7032



Pilot- and differential pressures

Function „spring closes“, closing with flow

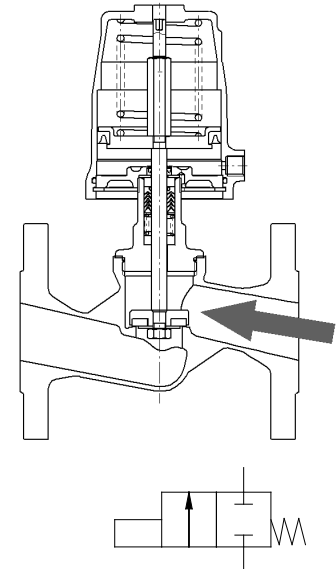

Seating seal PEEK-7

Nominal Size	Version	Actuator	Springs	Max. differential pressure [psi] at available pilot pressure [psi]													
				20	30	40	50	60	70	80	90	100	110	120	130	140	
1/2"	Standard	2"	2	0	0	0	32	365	580	580	580	580	580	580	580	580	
3/4"	Standard	3"	1	0	0	0	245	500	580	580	580	580	580	580	580	580	
		5"	1	290	580	580	580	580	580	580	580	580	580	580	580		
1"	Standard	3"	1	0	0	22	150	280	415	475	475	475	475	475	475	475	
		5"	1	165	475	475	475	475	475	475	475	475	475	475	475		
1 1/4"	Standard	3"	2	0	0	26	100	175	250	325	400	475	505	505	505	505	
		5"	1	100	285	475	505	505	505	505	505	505	505	505	505		
1 1/2"	Standard	3"	2	0	0	0	40	91	140	190	240	290	330	330	330	330	
		5"	2	0	79	205	330	330	330	330	330	330	330	330	330		
	d16	5"	2	0	76	200	320	445	570	580	580	580	580	580	580		
2"	Standard	5"	2	0	51	125	205	215	215	215	215	215	215	215	215	215	
		10"	2	0	48	125	200	280	355	435	510	550	550	550	550		
	d16	6	41	200	360	520	550	550	550	-	-	-	-	-			
2 1/2"	Standard (d16)	5"	3	0	0	37	80	120	165	205	250	295	335	360	360	360	
		10"	6	23	110	200	290	360	360	360	-	-	-	-	-		
3"	Standard (d16)	5"	3	0	0	25	55	85	115	140	170	200	230	260	290	290	
		10"	6	15	77	135	200	260	290	290	-	-	-	-	-		
4"	Standard (d16)	10"	8	0	28	60	91	120	155	185	-	-	-	-	-		
5"	Standard (d16)	10"	10	0	10	31	51	71	92	110	-	-	-	-	-		
6"	Standard (d16)	10"	12	0	2	16	30	44	58	72	-	-	-	-	-		

d16: reinforced design with 16mm (0.63") piston rod
 PEEK 7: Seating seal made of PEEK for use below 320°F
 PEEK 8: Seating seal made of PEEK for use above 320°F

Pressures/temperature mapping

PT rating PN40 for body made of 1.4408 1/2"- 3"

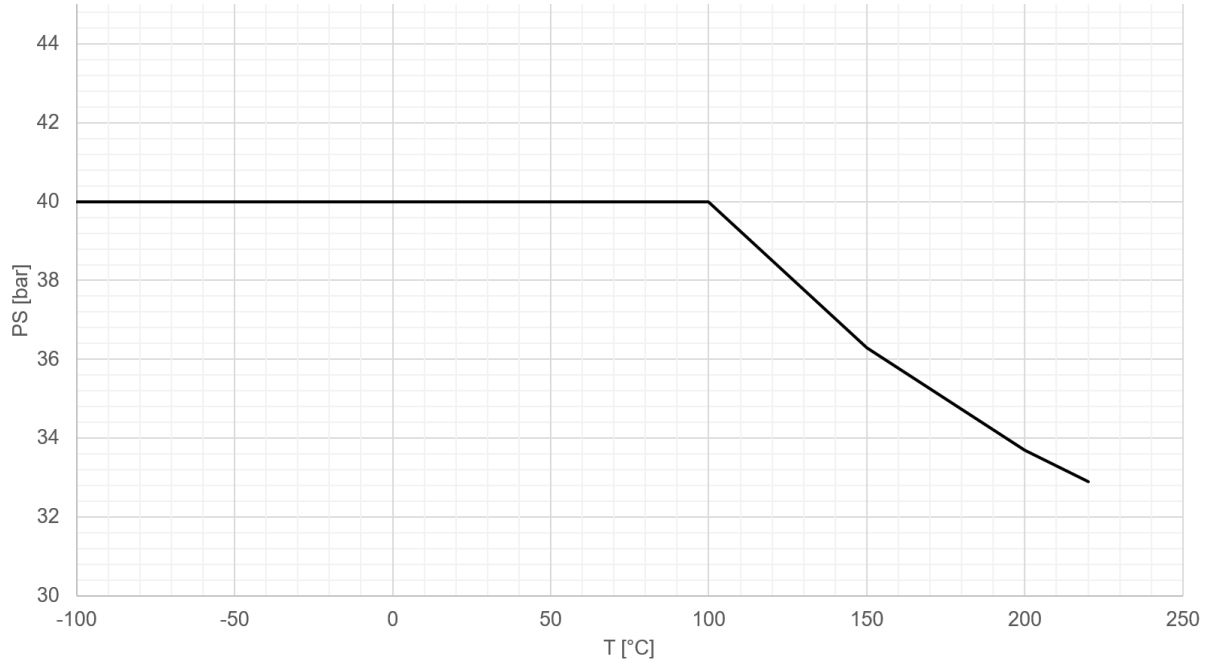

The maximum permissible pressure PS must not be exceeded, even if the driving force would allow this.

PT rating PN16 for body made of 1.4308 4"- 6"

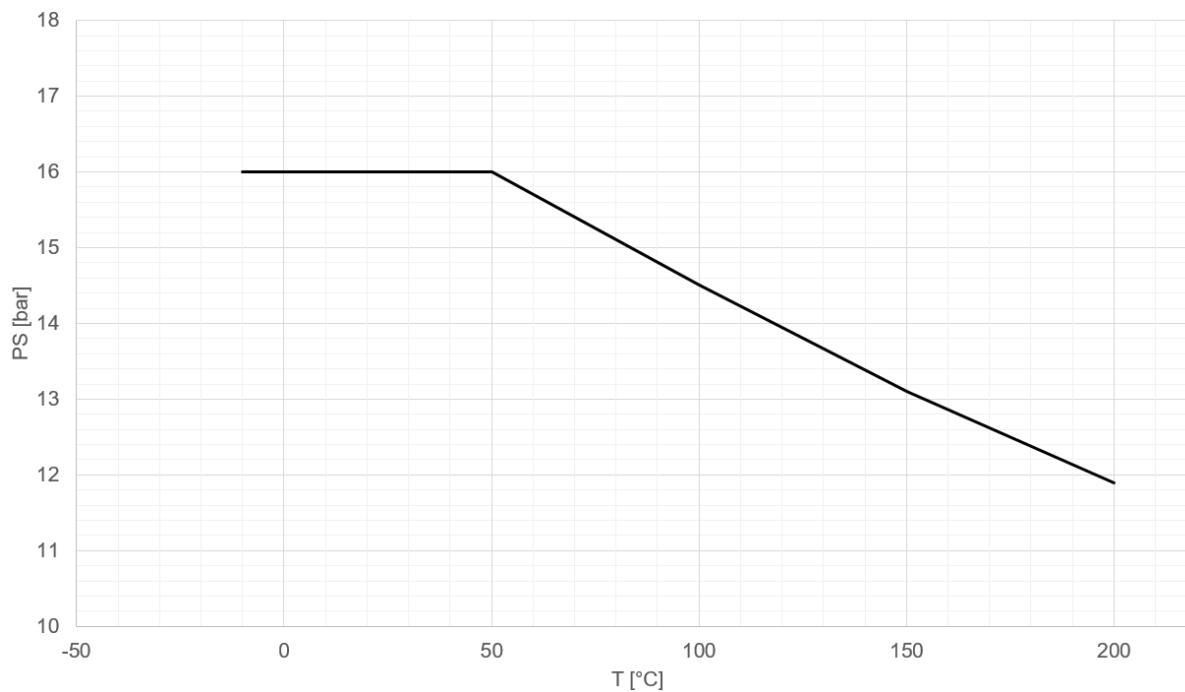

The maximum permissible pressure PS must not be exceeded, even if the driving force would allow this.

Ordering Number System

7	0	3	2	/			V							S
Model					Size			Symbol: "V": Valve "A": Actuator (valve without body) "R": Repair kit (sealings)						

1 - 6 : Please quote all 6 sections.
7 - 12: Quote only if required.

1. Body type	2. Connection	3. Body material	4. Seating seal	5. Pilot function	6. Actuator
9	flanged valve	2 stainless steel	0 PTFE (Teflon) 1 FKM (Viton) 2 EPDM 3 NBR (standard quality) 6 Vulkollan 7 PEEK 7 8 PEEK 8	0 NC (closing with flow) 1 NO (closing against flow) 2 NC (closing against flow) 3 Universal, double acting 5 NC, pressure balanced	7 piston Ø 2", NPT 8 piston Ø 3", NPT 9 piston Ø 5", NPT P piston Ø 2" with plastic bonnet, NPT S piston Ø 3" with plastic bonnet, NPT D diaphragm 10", NPT
	1 flange acc. DIN EN 1092-1 PN40 2 ANSI 150 flange length acc. ANSI/ISA-75.08.01 3 flange acc. DIN EN 1092-1 PN16				
7. Springs	8	9. Packing	10. Temperature version	11. Accessories	12. Special versions
- standard 1 1 spring 2 2 springs 3 3 springs T 6 springs (10") W 8 springs (10") Y 12 springs (10")	-	- standard 2 packing underneath	- standard H high temperature version +392°F B high temperature HT220 (428°F) U low temperature version down to -58°F, fluid temperature W low temperature version, down to -40°F, ambient temperature	- no accessories 1 electrical position indicator with one switch 2 as above but with two switches 3 manual emergency operation 4 additional manual operation 5 stroke limitation 6 pilot valve DN 2, 230 V AC 7 pilot valve DN 2, 24 V DC K electr. position indicator compact P position indicator with one ind. switch 10 - 36 V DC (PNP) T position indicator compact, inductive 10 - 30 V DC (PNP)	S Special versions M Position indicator with cable bushing N Position indicator with plug connection

Ordering example: 7032/050V922028----5
Flanged valve type 7032, size 2", connection ANSI150 flange, body material stainless steel, seating seal PTFE, NC closing against flow, actuator 3" NPT, stroke limitation.

Reinforced design "K" (from 1 1/2" and 2"):

Ordering example: 7032/050V92202D-----S--K
Flanged valve type 7032, DN 2", connection ANSI 150 flange, stainless steel body, PTFE seating seal, spring closes, closing against flow, actuator 10" NPT, reinforced design

Execution with bellows "F"

Ordering examples: 7032/050V922028----5S-F
Flanged Valve Type 7032, DN 2", connection ANSI 150 flange, stainless steel body, PTFE seating seal, spring closes, closing against flow, actuator 3" NPT, stroke limitation, large head with bellow

In addition to the listed options, there are a variety of other options available.

Flanged Valve 7032

1/2" - 2" Standard

Dimensions and Weights

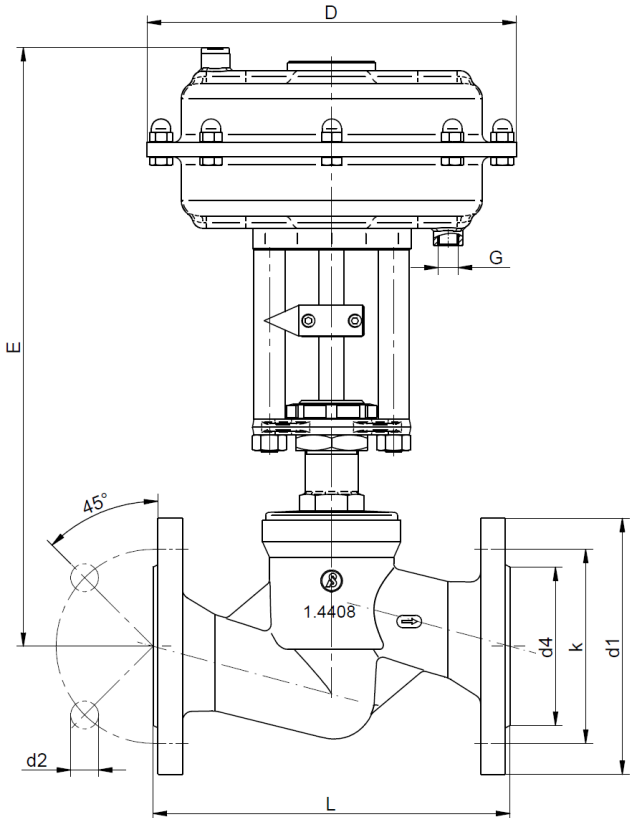
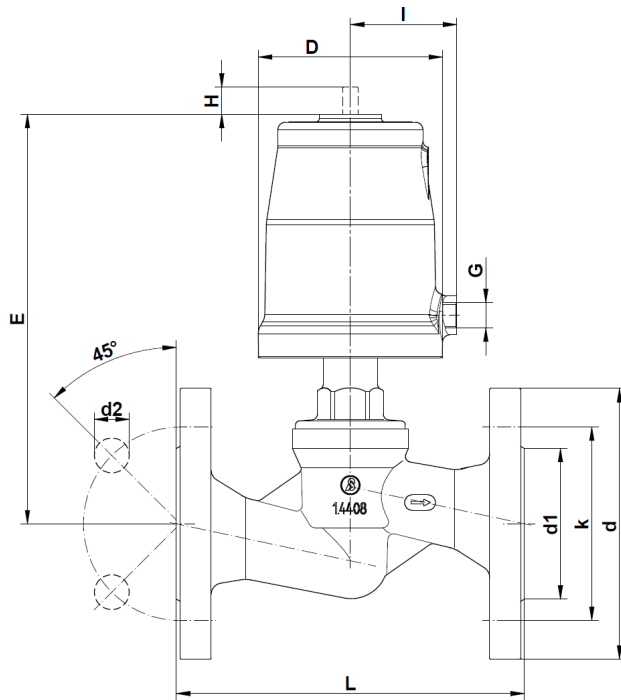

DN	Actuator	D	Flanges acc. EN 1092-1 Face to face dimension acc. EN 558-1					Flanges acc. ASME B16.5 Face to face dimension acc. ANSI/ISA-75.08.01					E	G	Stroke	I	Cvs-Valves	Weight (lbs)
			L	d	d1	d2	k	L	d	d1	d2	k						
1/2"	2"	2.44	5.12	3.74	1.77	0.55	2.56	7.24	3.5	1.38	0.62	2.38	5.79	1/8"	0.47	1.36	4	5,5
3/4"	2"	2.44	5.91	4.13	2.28	0.55	2.95	7.24	3.88	1.69	0.62	2.75	5.98	1/8"	0.61	1.36	8	7,3
1"	2"	2.44	6.3	4.53	2.68	0.55	3.35	7.24	4.25	2	0.62	3.12	6.65	1/8"	0.61	1.36	14	8,6
1"	3"	3.86	6.3	4.53	2.68	0.55	3.35	7.24	4.25	2	0.62	3.12	8.19	1/4"	0.79	2.17	14	12,1
1 1/4"	2"	2.44	7.09	5.51	3.07	0.71	3.94	7.87	4.62	2.5	0.62	3.5	6.81	1/8"	0.61	1.36	20	12,1
1 1/4"	3"	3.86	7.09	5.51	3.07	0.71	3.94	7.87	4.62	2.5	0.62	3.5	8.35	1/4"	0.91	2.17	20	15,4
1 1/4"	5"	5.67	7.09	5.51	3.07	0.71	3.94	7.87	4.62	2.5	0.62	3.5	9.29	1/4"	0.91	3.15	20	20,3
1 1/2"	2"	2.44	7.87	5.91	3.46	0.71	4.33	8.74	5	2.88	0.62	3.88	7.05	1/8"	0.61	1.36	29	14,6
1 1/2"	3"	3.86	7.87	5.91	3.46	0.71	4.33	8.74	5	2.88	0.62	3.88	8.58	1/4"	1.12	2.17	29	17,9
1 1/2"	5"	5.67	7.87	5.91	3.46	0.71	4.33	8.74	5	2.88	0.62	3.88	9.53	1/4"	1.12	3.15	29	22,7
2"	3"	3.86	9.06	6.5	4.02	0.71	4.92	10	6	3.62	0.75	4.75	9.49	1/4"	1.18	2.17	47	22,3
2"	5"	5.67	9.06	6.5	4.02	0.71	4.92	10	6	3.62	0.75	4.75	10.47	1/4"	1.18	3.15	47	27,1

Reinforced version

1 1/2"	10"	9.37	7.87	5.91	3.46	0.71	4.33	8.74	5	2.88	0.62	3.88	15.31	1/4"	0.98	-	29	37,5
2"	10"	9.37	9.06	6.5	4.02	0.71	4.92	10	6	3.62	0.75	4.75	15.16	1/4"	0.98	-	47	42,3

dimensions in inch

Flanged Valve 7032

2 1/2" - 3"

Dimensions and Weights

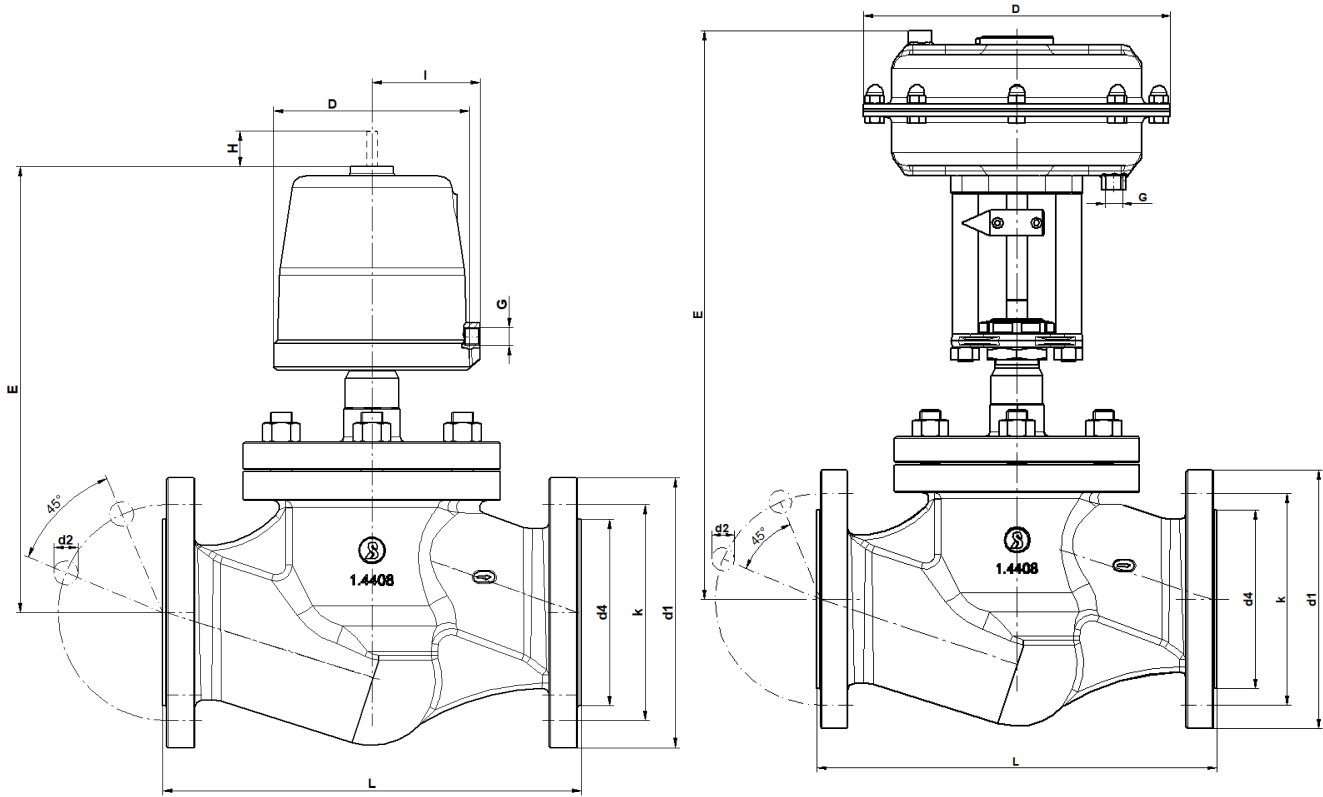

DN	Actuator	Flanges acc. EN 1092-1					D	E	H	G	Stroke	Cvs-Value	Weight (kg)
		Face to face dimension acc. EN 558-1											
		L	d1	d2	d4	k							
2 1/2"	3"	11.42	7.28	0.71	4.8	5.71	3.78	11.61	1.02	G1/4"	1.06	69	50.7
2 1/2"	5"	11.42	7.28	0.71	4.8	5.71	5.75	12.6	1.02	G1/4"	1.06	69	55.1
2 1/2"	10"	11.42	7.28	0.71	4.8	5.71	9.37	16.93	-	G1/4"	0.98	69	66.1
3"	3"	12.2	7.87	0.71	5.43	6.3	3.78	12.01	1.02	G1/4"	1.06	98	66.1
3"	5"	12.2	7.87	0.71	5.43	6.3	5.75	12.99	1.02	G1/4"	1.06	98	70.5
3"	10"	12.2	7.87	0.71	5.43	6.3	9.37	17.52	-	G1/4"	0.98	98	79.4

dimensions in inch

Flanged Valve 7032

4" - 6"

Dimensions and Weights

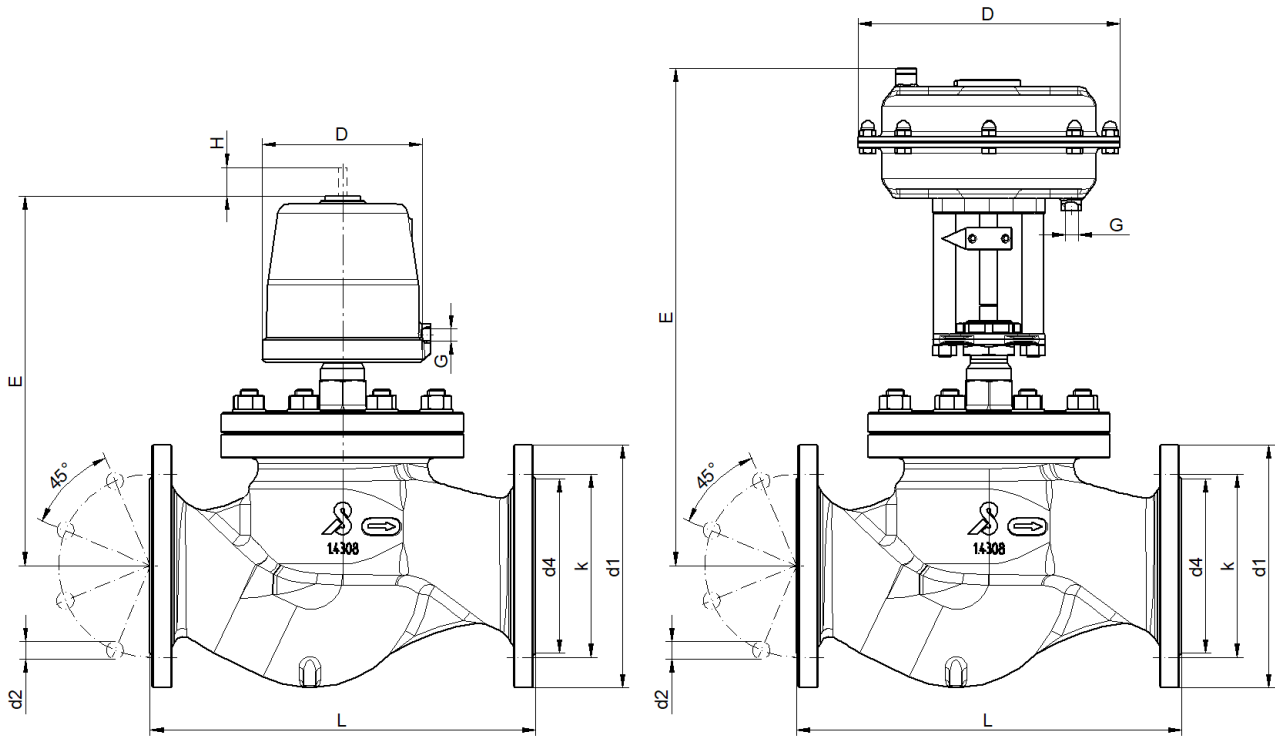

DN	Actuator	Flanges acc. EN 1092-1 Face to face dimension acc. EN 558-1					D	E	H	G	Stroke	Cvs-Value	Weight (lbs)
		L	d1	d2	d4	k							
4"	3"	13.78	8.661	0.709	6.22	7.087	3.78	12.205	1.024	G1/4"	1.063	215	90.4
4"	5"	13.78	8.661	0.709	6.22	7.087	5.748	13.228	1.024	G1/4"	1.142	215	92.6
4"	10"	13.78	8.661	0.709	6.22	7.087	9.37	17.795	-	G1/4"	0.945	215	103.6
5"	5"	15.748	9.843	0.709	7.402	8.268	5.748	14.094	1.024	G1/4"	1.142	283	127.9
5"	10"	15.748	9.843	0.709	7.402	8.268	9.37	18.661	-	G1/4"	0.945	283	138.9
6"	5"	18.898	11.22	0.709	8.346	9.449	5.748	15.118	1.024	G1/4"	1.142	363	187.4
6"	10"	18.898	11.22	0.709	8.346	9.449	9.37	19.685	-	G1/4"	0.945	363	198.4

dimensions in inch

Flanged Valve 7032



1/2" - 2" Execution HT220

Dimensions and Weights

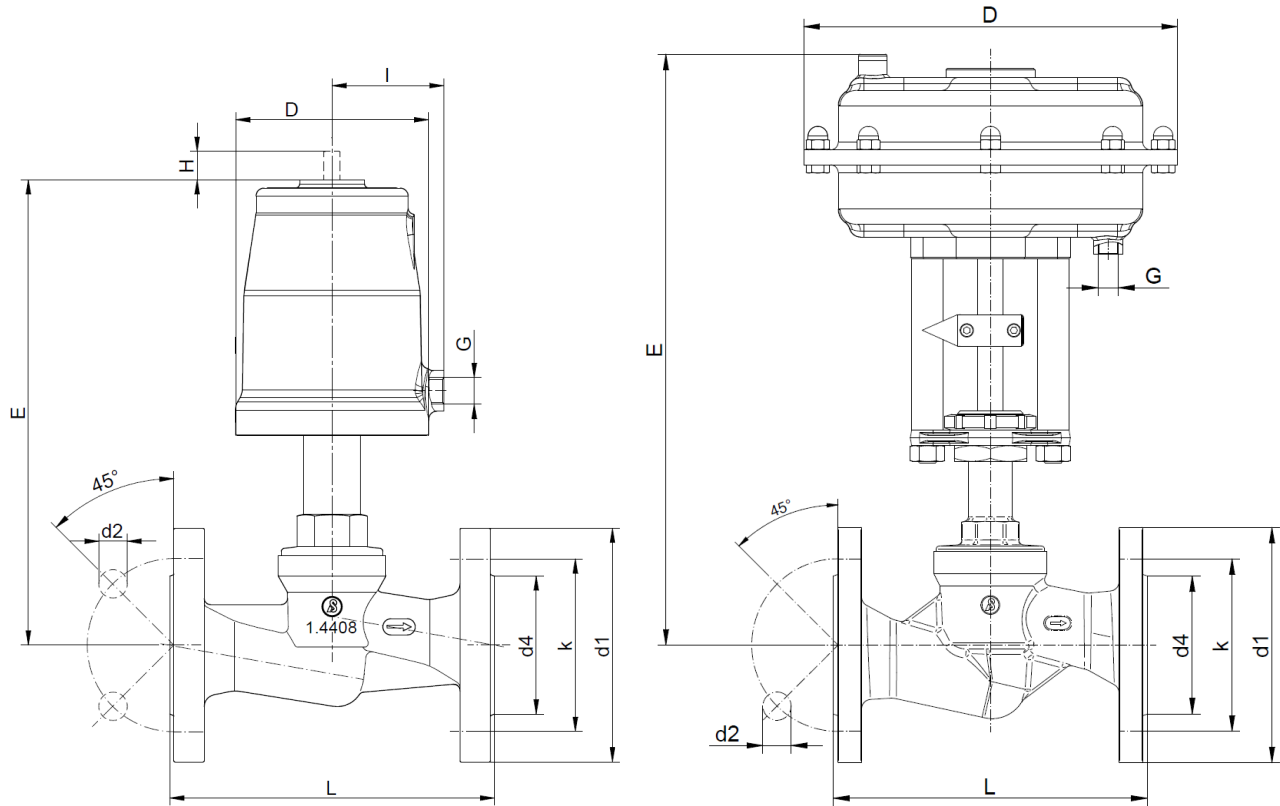

DN	Actuator	D	Flanges acc. EN 1092-1 Face to face dimension acc. EN 558-1					Flanges acc. ASME B16.5 Face to face dimension acc. ANSI/ISA-75.08.01					E	G	Stroke	I	Cvs-Values	Weight (lbs)
			L	d	d1	d2	k	L	d	d1	d2	k						
1/2"	2"	2.44	5.12	3.74	1.77	0.55	2.56	7.24	3.5	1.38	0.62	2.38	6.65	1/8"	0.47	1.36	4	7.1
3/4"	2"	2.44	5.91	4.13	2.28	0.55	2.95	7.24	3.88	1.69	0.62	2.75	6.85	1/8"	0.61	1.36	8	8.8
1"	2"	2.44	6.3	4.53	2.68	0.55	3.35	7.24	4.25	2	0.62	3.12	7.52	1/8"	0.61	1.36	14	10.1
1"	3"	3.86	6.3	4.53	2.68	0.55	3.35	7.24	4.25	2	0.62	3.12	8.98	1/4"	0.79	2.17	14	13.7
1 1/4"	2"	2.44	7.09	5.51	3.07	0.71	3.94	7.87	4.62	2.5	0.62	3.5	7.68	1/8"	0.61	1.36	20	13.7
1 1/4"	3"	3.86	7.09	5.51	3.07	0.71	3.94	7.87	4.62	2.5	0.62	3.5	9.13	1/4"	0.91	2.17	20	17
1 1/4"	5"	5.67	7.09	5.51	3.07	0.71	3.94	7.87	4.62	2.5	0.62	3.5	10.16	1/4"	0.91	3.15	20	21.8
1 1/2"	2"	2.44	7.87	5.91	3.46	0.71	4.33	8.74	5	2.88	0.62	3.88	7.91	1/8"	0.61	1.36	29	16.1
1 1/2"	3"	3.86	7.87	5.91	3.46	0.71	4.33	8.74	5	2.88	0.62	3.88	9.41	1/4"	1.12	2.17	29	19.4
1 1/2"	5"	5.67	7.87	5.91	3.46	0.71	4.33	8.74	5	2.88	0.62	3.88	10.39	1/4"	1.12	3.15	29	24.3

Reinforced version

1 1/2"	3"	3.86	7.87	5.91	3.46	0.71	4.33	8.74	5	2.88	0.62	3.88	10	1/4"	1.12	2.17	29	19.6
1 1/2"	5"	5.67	7.87	5.91	3.46	0.71	4.33	8.74	5	2.88	0.62	3.88	10.98	1/4"	1.12	3.15	29	24.5
2"	3"	3.86	9.06	6.5	4.02	0.71	4.92	10	6	3.62	0.75	4.75	14.88	1/4"	1.18	2.17	47	24
2"	5"	5.67	9.06	6.5	4.02	0.71	4.92	10	6	3.62	0.75	4.75	11.93	1/4"	1.18	3.15	47	28.9
1 1/2"	10"	9.37	7.87	5.91	3.46	0.71	4.33	8.74	5	2.88	0.62	3.88	16.18	1/4"	0.98	-	29	39.2
2"	10"	9.37	9.06	6.5	4.02	0.71	4.92	10	6	3.62	0.75	4.75	16.02	1/4"	0.98	-	47	44.1

dimensions in inch

Flanged Valve 7032

1/2" - 2" Execution with bellows

Dimensions and Weights

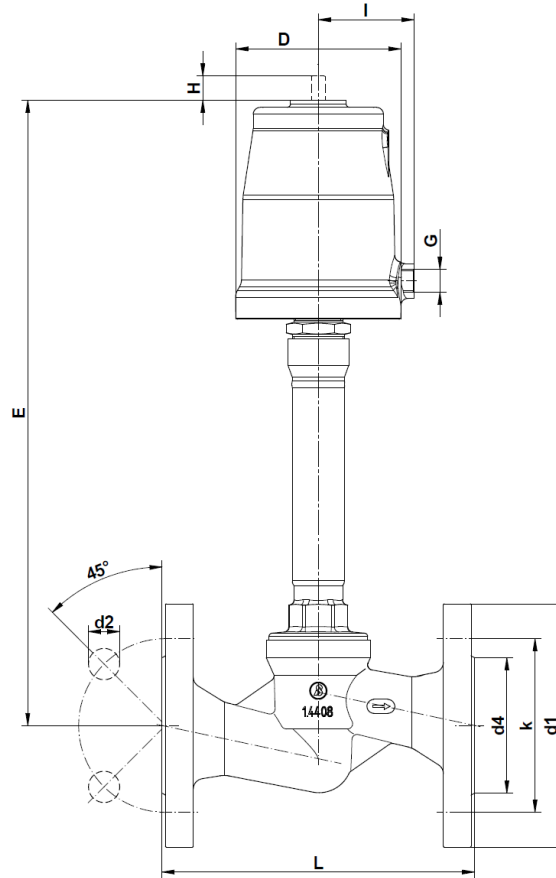

DN	Actuator	D	Flanges acc. EN 1092-1					Flanges acc. EN 1092-1					E	G	Stroke	I	Cvs-Values
			Face to face dimension acc. EN 558-1					Face to face dimension acc. EN 558-1									
			L	d	d1	d2	k	L	d	d1	d2	k					
1/2"	2"	2.44	5.12	3.74	1.77	0.55	2.56	7.24	3.5	1.38	0.62	2.38	11.81	1/8"	0.47	1.36	3.6
3/4"	2"	2.44	5.91	4.13	2.28	0.55	2.95	7.24	3.88	1.69	0.62	2.75	11.97	1/8"	0.61	1.36	7.5
1"	2"	2.44	6.3	4.53	2.68	0.55	3.35	7.24	4.25	2	0.62	3.12	12.52	1/8"	0.61	1.36	13.9
1"	3"	3.86	6.3	4.53	2.68	0.55	3.35	7.24	4.25	2	0.62	3.12	14.02	1/4"	0.79	2.17	13.9
1 1/4"	3"	3.86	7.09	5.51	3.07	0.71	3.94	7.87	4.62	2.5	0.62	3.5	14.17	1/4"	0.91	2.17	20.2
1 1/4"	5"	5.67	7.09	5.51	3.07	0.71	3.94	7.87	4.62	2.5	0.62	3.5	15.16	1/4"	0.91	3.15	20.2
1 1/2"	3"	3.86	7.87	5.91	3.46	0.71	4.33	8.74	5	2.88	0.62	3.88	14.41	1/4"	1.12	2.17	28.9
1 1/2"	5"	5.67	7.87	5.91	3.46	0.71	4.33	8.74	5	2.88	0.62	3.88	15.39	1/4"	1.12	3.15	28.9
2"	3"	3.86	9.06	6.5	4.02	0.71	4.92	10	6	3.62	0.75	4.75	15.35	1/4"	1.18	2.17	46.2
2"	5"	5.67	9.06	6.5	4.02	0.71	4.92	10	6	3.62	0.75	4.75	16.3	1/4"	1.18	3.15	46.2

dimensions in inch

Flanged Valve 7032

1/2" - 1 1/2" Manual actuator

Dimensions and Weights

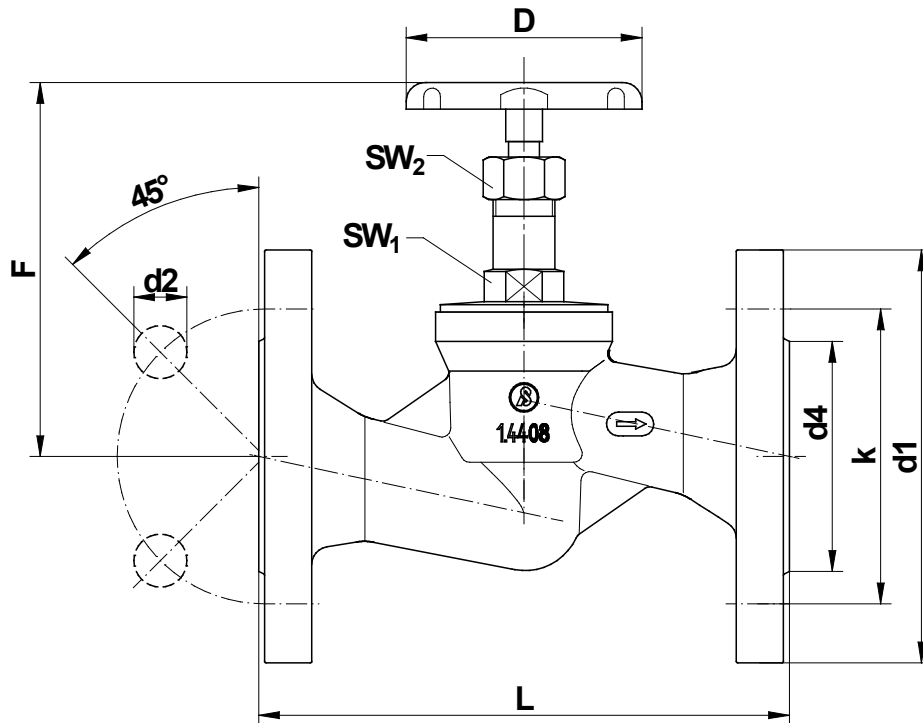

Size	L	D	d1	d2	d4	k	F open	F closed	SW1	SW2
1/2"	5.12	2.76	3.74	0.55	1.77	2.56	4.21	3.66	0.75	0.79
3/4"	5.91	2.76	4.13	0.55	2.28	2.95	4.8	4.13	0.75	0.79
1"	6.3	3.15	4.53	0.55	2.68	3.35	5.43	4.61	0.94	0.94
1 1/4"	7.09	3.15	5.51	0.71	3.07	3.94	7.13	5.75	0.94	0.94
1 1/2"	7.87	3.94	5.91	0.71	3.46	4.33	5.94	5	1.06	1.06

The maximum differential pressures for manual valves are equivalent to the maximum pressures of the pressure ratings. (see p.12)

Flanged Valve 7032

1/2" - 3" GS manual actuator

Dimensions and Weights

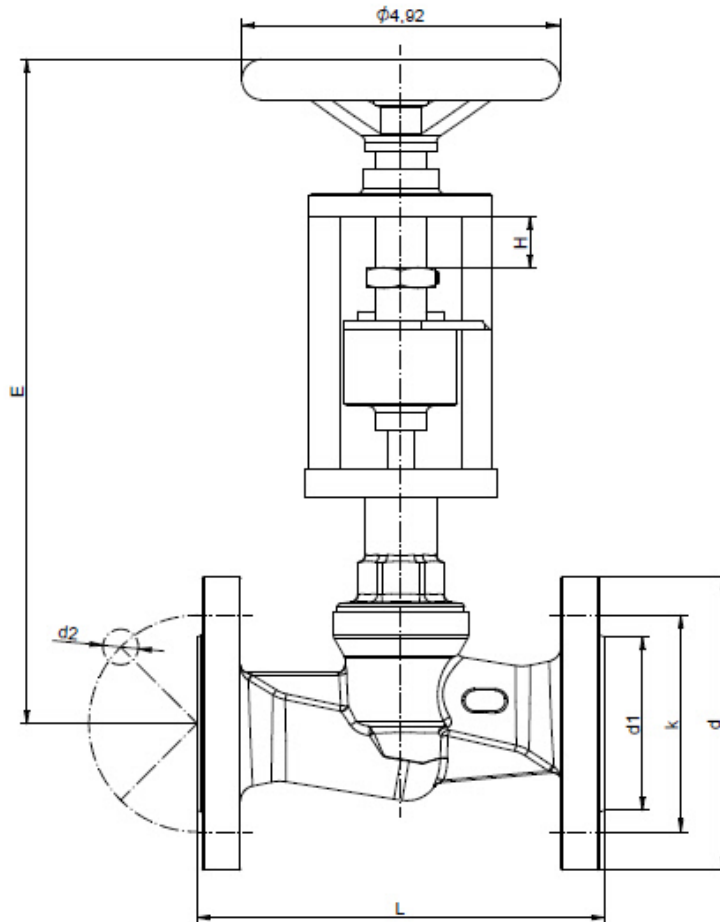

DN	L	d	d1	d2	k	n	E Closed	Stroke H
1/2"	5,12	3,74	1,77	0,55	2,56	4	10	0,47
3/4"	5,91	4,13	2,28	0,55	2,95	4	10,04	0,61
1"	6,3	4,53	2,68	0,55	3,35	4	10,59	0,79
1 1/4"	7,09	5,51	3,07	0,71	3,94	4	10,63	0,91
1 1/2"	7,87	5,91	3,46	0,71	4,33	4	10,63	1,12
2"	9,06	6,5	4,02	0,71	4,92	4	11,57	1,18
2 1/2"	11,42	7,28	4,8	0,71	5,71	8	13,66	1,06
3"	12,2	7,87	5,43	0,71	6,3	8	14,09	1,06

The maximum differential pressures for manual valves are equivalent to the maximum pressures of the pressure ratings. (see p.12)

Temperature versions

Version	Description	Fluid temperature	Ambient temperature
1	Standard - Stainless steel	-22°F up to +338°F	+5°F up to +140°F
2	HT220 - version, only with PEEK seating seal	-22°F up to +428°F	+5°F up to +212°F
3	High temperature version in stainless steel	-22°F up to +392°F	+5°F up to +212°F
4	Low temperature version acc. to drawing R0194 for stainless steel body	-58°F up to +275°F	+5°F up to +140°F
5	Low temperature version acc. to drawing R0188 for stainless steel body		-40°F up to +140°F
6	Low temperature version for stainless steel body	-40°F up to + 338°F	+5°F up to +140°F
7	Bonnet for actuator made of polymer for stainless steel body	-22°F up to +275°F	+5°F up to +140°F
8	Low temperature version with bonnet for actuator made of polymer and stainless steel body	-40°F up to +275°F	+5°F up to +140°F
9	Long head section (without bellows)	-94°F up to +392°F	+5°F up to +140°F
10	Long head section with bellows	-148°F up to +392°F	+5°F up to +140°F
11	Standard, stainless steel with seals from NBR	-22°F up to +338°F	-22°F up to +140°F
12	Low temperature version, seating seal made of NBR and stainless steel body	-40°F up to +338°F	-40°F up to +140°F
13	Diaphragm actuator D250	-22°F up to +392°F	-22°F up to +140°F
14	Low temperature version for diaphragm actuator D250	-40°F up to +392°F	-22°F up to +140°F