

Motorized Segmented disc valves 5030

DN 25 bis DN 300 DN800 on request

Pneumatic control valve for the control of liquids and steam.

- suitable for contaminated fluids
- robust design
- tight in both directions
- controllable in both directions
- space saving wafer type construction
- quiet operation
- high KVs-values

Technical data

Body design	flangeless, wafer-type construction for flanges acc. DIN EN 1092-1, form B	
Nominal size	DN25 to DN200	
Nominal pressure	DN25 to DN150	PN 25 acc. DIN 2401 (also for flanges PN 10 to PN 25)
	DN 200	PN 25 acc. DIN 2401
	DN 250 to DN 300	PN 16 acc. DIN 2401
Fluid temperature	-60°C up to 220°C	
Ambient temperature*	-30°C up to +100°C	
Rangeability	60:1	
Characteristic	modified linear	
Leakage % of Kvs	<0,001	

* Please consider the limitation of use of the actionator!

Materials

body	Stainless steel 1.4571
rack	Stainless steel 1.4112, treated
pressure spring	Stainless steel 1.4310
Fixed valve plate	Stainless steel 1.4112, treated
Moving valve disc	Stainless steel 1.4112, treated
slide ring	Stainless steel 1.4112, treated alternatively bronze
spring support	Stainless steel 1.4571
wear ring	Stainless steel 1.4571

Actuators

There are various types of actuators available.

For technical data on the actuators please consult the corresponding data sheets.



Admissible Differential Pressure (For temperatures of up to 120°C)

**For temperatures of 120°C and above:
obey application limits !**

Actuators Type 2030 (On-Off and Control)

force	2 kN	5 kN
DN	max. differential pressure in flow direction (against flow direction) [bar]	
25	25 (16)	25 (25)
32	25 (11)	25 (25)
40	25 (8)	25 (22)
50	17 (5)	25 (16)
65	12 (4)	25 (11)
80	7 (3)	25 (9)
100	3 (2)	21 (6)

PSL-actuators

On-Off

size of the actuator	PSL 204	PSL 210	PSL 320	PSL 325
force	4,5 kN	18 kN	20 kN	25 kN
DN	max. differential pressure in flow direction (against flow direction) [bar]			
25	25 (25)			
32	25 (25)			
40	25 (20)			
50	25 (14)	25 (25)		
65	25 (10)	25 (25)		
80	25 (8)	25 (25)		
100	17 (5)	25 (21)		
125	14 (5)	25 (20)	25 (25)	25 (25)
150	-	25 (13)	25 (17)	25 (22)
200	-	-	25 (9)	25 (12)
250	-	-	16 (6)	16 (7)
300	-	-	16 (4)	16 (5)

Control

size of the actuator	PSL 204-AMS11	PSL 210-AMS11	PSL 214-AMS12	PSL 320-AMS13	PSL 325-AMS13
force	2,3 kN	5 kN	7 kN	10 kN	12,5 kN
DN	max. differential pressure in flow direction (against flow direction) [bar]				
25	25 (19)	25 (25)			
32	25 (13)	25 (25)			
40	25 (9)	25 (22)	25 (25)		
50	22 (6)	25 (16)	25 (22)		
65	15 (4)	25 (11)	25 (16)		
80	9 (3)	25 (9)	25 (13)		
100	5 (2)	21 (6)	25 (9)		
125	-	17 (5)	25 (8)	25 (12)	25 (15)
150	-	9 (4)	19 (5)	25 (8)	25 (10)
200	-	-	-	24 (4)	25 (6)
250	-	-	-	15 (3)	16 (3)
300	-	-	-	9 (2)	14 (2)

Ordering Number System

Ordering Number:

	4030/																			Z	...	
Nominal Size																						
e.g. DN 25 = 025		xxx																				
Item																						
valve			V																			
seat kit				D																		
lower valve part					U																	
Design																						
SPV1 flangeless design PN25 (from DN250 PN16) (for flanges acc. DIN EN 1092-1, Form B)						1																
Body material																						
stainless steel 1.4571 or 1.4112							1															
Safety position																						
no safety position in case of power failure																						
Fail Safe Function: Safety position closed in the case of power failure																						0
Fail Safe Function: Safety position opened in the case of power failure																						1
Actuator																						
without																						-
2kN, Type 2030 position electronic, IP67, incl. fault alarm output																						6
5kN, Type 2030 position electronic, IP67, incl. fault alarm output																						7
Electric linear actuator (control), brand PS-Automation, Typ PSL204-AMS11																						1
Electric linear actuator (control), brand PS-Automation, Typ PSL210-AMS11																						2
Electric linear actuator (control), brand PS-Automation, Typ PSL214-AMS12																						3
Electric linear actuator (control), brand PS-Automation, Typ PSL320-AMS13																						4
Electric linear actuator (control), brand PS-Automation, Typ PSL325-AMS13																						5
Electric linear actuator (On-Off-Service), brand PS-Automation, Typ PSL204																						A
Electric linear actuator (On-Off-Service), brand PS-Automation, Typ PSL320																						C
Electric linear actuator (On-Off-Service), brand PS-Automation, Typ PSL325																						D
Electric linear actuator (On-Off-Service), brand PS-Automation, Typ PSL210																						P
Special actuator (see following position)																						S
Special versions																						
(Standard) not encapsulated version																						M
encapsulated version																						K
Motor voltage:																						
230V 50/60Hz																						-
3 x 400V, 50/60Hz																						6
Stem sealing																						
Standard (gland)																						-
Interior sealings																						
Standard (PTFE)																						-
EPDM																						1
Moving valve disc																						
Standard, stainless steel 1.4112, treated																						-
Carbon steel 1.7131, treated																						1
Fixed valve plate																						
Standard, stainless steel 1.4112, treated																						-
Carbon steel 1.7131, treated																						1
Kvs (CV) value / Characteristic																						
Linear 100% (Stand.)																						-
special characteristics																						X

Bestellbeispiel: 5030/050V110P

PS- SP-motor valve, nominal size 50, material: stainless steel. without safety position, actuator type Automation Type 210

Installation dimensions with actuator Type 2030

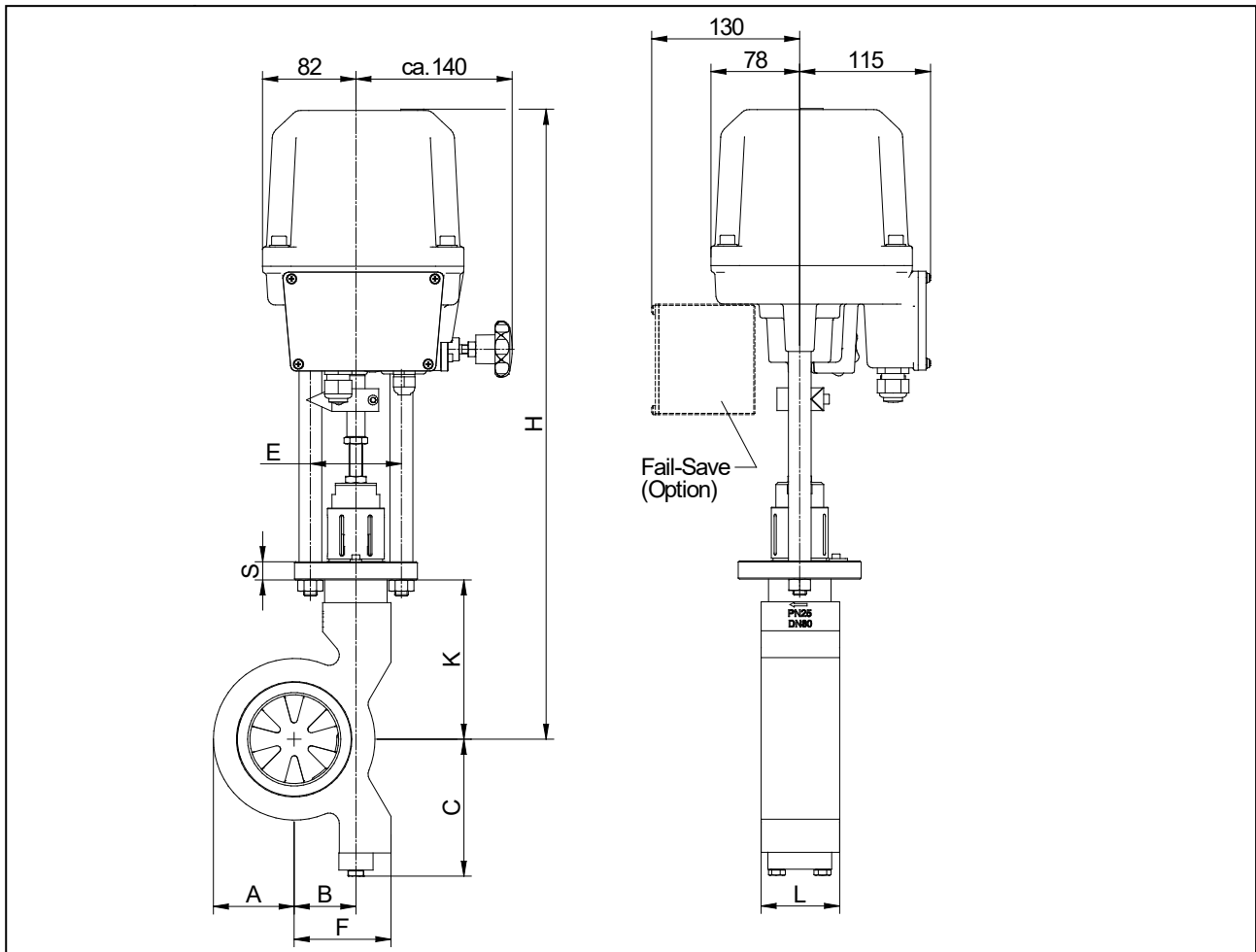

DN	A	B	C	E	F	K	L	S	Stroke	Actuator 2 kN		Actuator 5 kN	
										H	Weight	H	Weight
25	35	25	70	100	49	99,5	39	16	24	457	12,8	489	14,5
32	41	30	78	100	53,5	112	39	16	28	470	14,3	502	16
40	46	33	82	100	59	103	45	16	32	461	15	493	16,7
50	53,5	41	100	100	68,5	125	56	16	29	524	17,8	556	19,5
65	63,5	50	96	100	76,5	147,5	63	16	23	546	19,6	578	21,3
80	71	54	120	100	85	155	69	16	26	554	22,5	586	24,2
100	83	64	112	100	95	175	79	16	31	574	26,7	606	28,4

dimensions in mm

Notice:

The flanges from DN25 to DN50 have to be rotated by 45°, if the valve is to be installed vertically or horizontally.

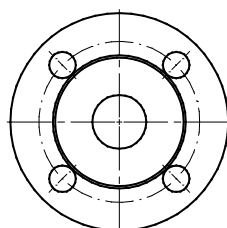

Standard

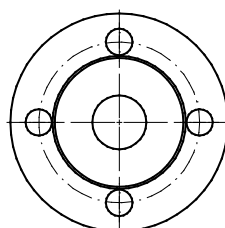

rotated 45°

Installation dimensions with PSL-actuators

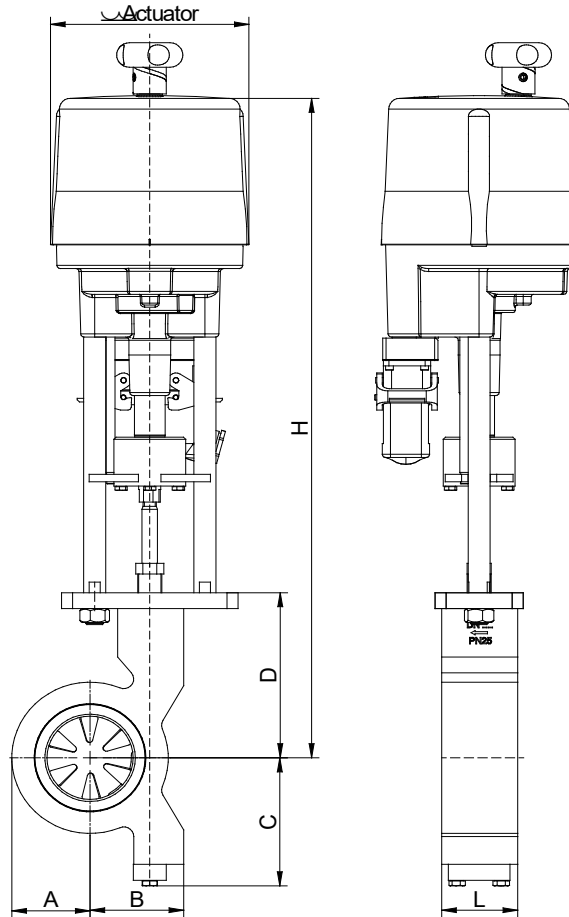

DN	A	B	C	D	L	Stroke	KVS [m³/h]	Actuator PSL 204			Actuator PSL 210			Actuator PSL 214			Actuator PSL 320			Actuator PSL 325		
								Ø D	H	Weight	Ø D	H	Weight	Ø D	H	Weight	Ø D	H	Weight	Ø D	H	Weight
25	35	49	70	99,5	39	24	6,8	177	616,5	11,5	---	---	---	---	---	---	---	---	---	---	---	---
32	41	53,5	78	112	39	28	15	177	629	12	---	---	---	---	---	---	---	---	---	---	---	---
40	46	59	82	103	45	32	24	177	620	12,7	---	---	---	---	---	---	---	---	---	---	---	---
50	53,5	68,5	100	125	56	29	38	177	642	15,5	177	644	17,5	---	---	---	---	---	---	---	---	---
65	63,5	76,5	96	147,5	63	23	52	177	664,5	17,3	177	666,5	19,3	180	730,5	21,3	---	---	---	---	---	---
80	71	85	120	155	69	26	87	177	672	20,2	177	674	22,2	180	738	24,2	---	---	---	---	---	---
100	83	95	112	175	79	31	171	177	692	24,4	177	694	26,4	180	758	28,4	---	---	---	---	---	---
125	97	108	139	185	79	37	275	177	702	30	177	704	32	180	768	34	250	905	45	250	905	45
150	112,5	130	182	220	129	45	410	---	---	---	177	739	56	180	803	58	250	940	69	250	940	69
200	142	162	193	235	159	60	600	---	---	---	---	---	---	---	---	---	250	955	112	250	955	112
250	160	195	217,5	280	153,2	74	1000	---	---	---	---	---	---	---	---	---	250	1000	142	250	1000	142
300	192	217	247,5	305	154	64	1440	---	---	---	---	---	---	---	---	---	250	1025	166	250	1025	166

dimensions in mm

Notice:

The flanges from DN25 to DN50 have to be rotated by 45°, if the valve is to be installed vertically or horizontally.

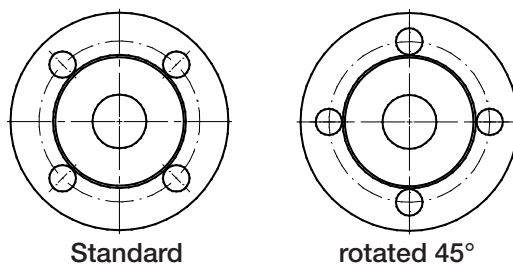

Installation dimensions DN 400 to DN 800

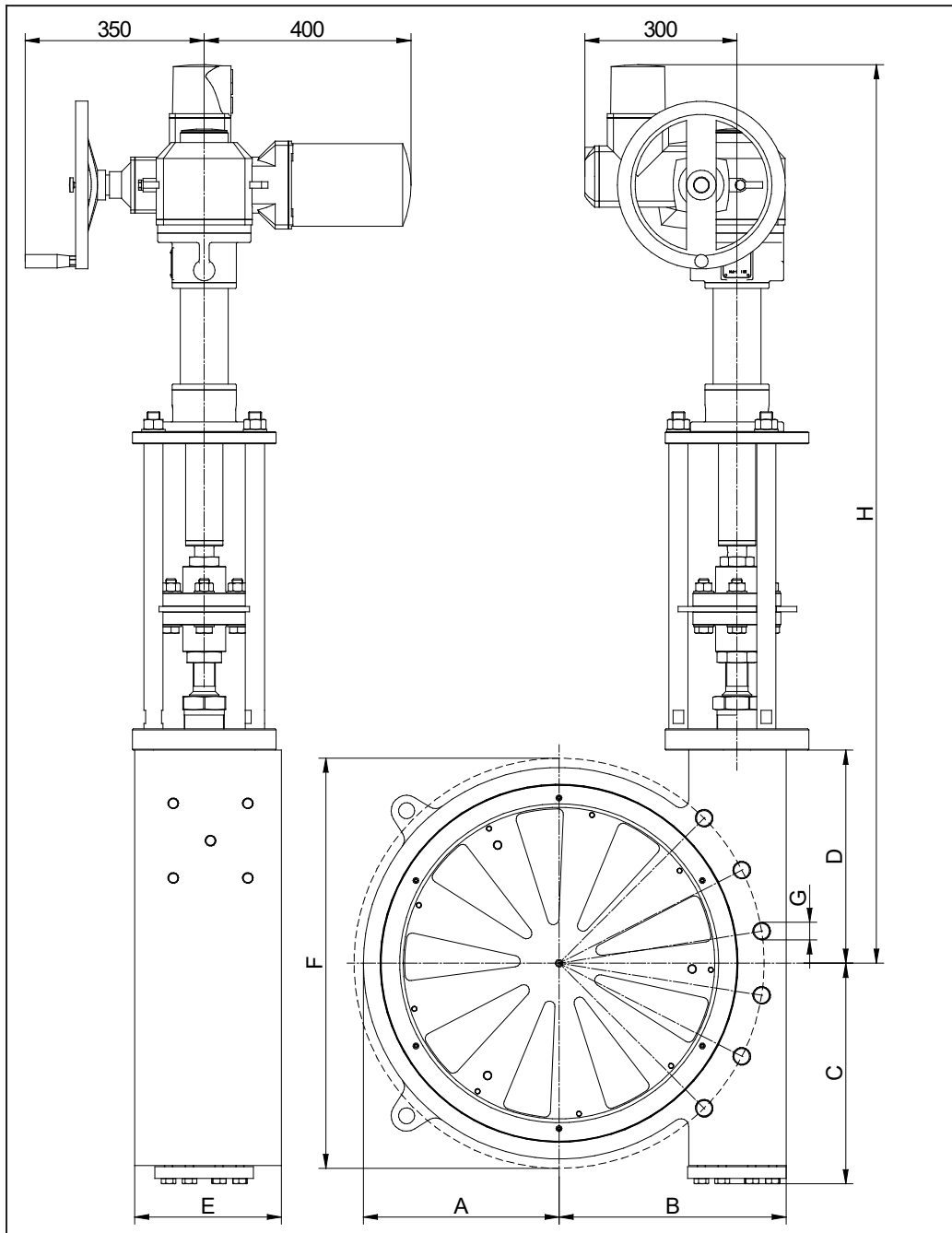

DN	A	B	C	D	E	F	G	H	number of screws	stroke	KV	weight * lower part	weight * incl. actuator
400	250	310	305	320	210	525	M27	1620	16	77	2190	385	470
500	310	350	335	340	228	650	M30	1640	20	95	3900	530	615
600	370	430	415	400	275,5	770	M33	1700	20	111	5650	861	946
700	405	465	505	420	295	840	M33	1720	24	144	7350	1100	1185
800	460	535	540	450	320	950	M36	1750	24	146	10400	1445	1530

* All dimensions and weights are approximate and depend on the actuator version.

Note:

Nominal sizes DN 400 to DN 800 may only be used in accordance with category I according to the pressure equipment order 2014/68/EU.