

Ball Sector Valve 4030

1" up to 12"

Motorvalve for the control of neutral and aggressive fluids

- 1" up to 12"
- High Cv-values up to 4454
- Excellent control characteristics
- Suitable for abrasive media
- Easily exchangeable seat ring
- Low maintenance
- Actuators can be easily fitted
- Efficient and easy to install
- Optional with face to face dimension acc. ANSI ISA 75.08.02



Technical Information Valve

Design		1" - 10" flangeless wafertype 12" flange connection
Nominal sizes		1" up to 12"
Body material	cast parts turned parts	CF8M (1.4408) 316L (1.4404)
Bearing material		high temperature plain bearing (Iglidur Z)
Connection to the actuator		mounting kit DIN/ISO 5211
Nominal pressure	1" - 2"	ANSI150, ANSI300, 580 psi (for flanges 145 psi - 580 psi)
	3" - 4"	ANSI150, ANSI300, 365 psi (for flanges 145 psi - 365 psi)
	6" - 12"	ANSI150, 235 psi (for flanges 145 psi - 235 psi)
Fluid Temperature		-40°F up to +428°F according to the sealings
Ambient temperature		-4°F up to +158°F special version on request according to the acuator
Vacuum		up to 1,48 mercury (Hg)
Characteristic		almost equal percentage
Rangeability		100:1
Classification DIN EN ISO15848-1		series KS2, DN25-DN250: ISO FE-BH-CC3-SSA0-t(-40°C/+220°C)-PN40-ISO 15848-1 series KS1; DN300: ISO FE-BH-CC-SSA0-t(RT)-PN16-ISO 15848-1

Working pressure max.

Nominal size	maximum differential pressure (delta p)									
	seat ring PTFE			seat ring PEEK				seat ring Stellite		
	up to 176°F	248°F	338°F	up to 176°F	248°F	338°F	428°F	up to 176°F	338°F	428°F
	psi	psi	psi	psi	psi	psi	psi	psi	psi	psi
1" - 2"	365	230	85	580	580	365	230	580	580	365
3" - 4"	230	175	75	365	365	230	145	365	365	230
6" - 12"	230	175	60	230	230	175	115	230	230	175

Actuators for mounting according DIN/ISO5211

Temperature limits

Seating	Sealing seating									
	Viton		EPDM		NBR		FFKM		PFA-Silicone	
	Tmin [°F]	Tmax [°F]	Tmin [°F]	Tmax [°F]	Tmin [°F]	Tmax [°F]	Tmin [°F]	Tmax [°F]	Tmin [°F]	Tmax [°F]
PTFE	5	338	-40	284	-22	212	5	338	-49	338
PEEK	5	392	-40	284	-22	212	5	428	-49	428
Stellite	5	392	-40	284	-22	212	5	428	-49	428

Leakage

Seat ring	Ball sector	Leakage	
		Amount of the max. Kvs-value	class acc. EN 60534-4: (IEC 60534-4)
PTFE or PEEK	stainless steel polished		VI
PTFE or PEEK	stainless steel hard chrome plated	5x10 ⁻⁷	IV-S1
Stellite	stainless steel, hard chrome plated + lapped	5x10 ⁻⁶	IV-S1

Cvs-Values

Size	Cvs-value reduced to					
	100%	63%	40%	25%	16%	6,3%
1"	29	14.7	9.2	6.2	4.2	1.7
1 1/2"	80.9	46.6	29			
2"	126	75.4	47.6			
2 1/2"	220.4					
3"	347					
4"	451					
5"	874					
6"	936					
8"	1578					
10"	2567					
12"	4439					

Operation time / 90° with standard actuator

Size	operation time / 90° [s]
1"	9
1 1/2"	13
2"	13
2 1/2"	29
3"	29
4"	34
5"	58
6"	58
8"	58

Torques and mounting kits

for retrofitting actuators

Size	rotation angle nominal	max. press. nominal PN	max. press. nominal ANSI	req. torque [lbf ft]		mounting kit ISO 5211 diagonal square shaft	
				on/off-operation	control operation	series 1	series 2
1"	90°	PN40	ANSI 300	11	18	F04/SW11	F05/SW14
1 1/2"	90°	PN40	ANSI 300	22	37	F05/SW14	F07/SW17
2"	90°	PN40	ANSI 300	22	37	F05/SW14	F07/SW17
2 1/2"	90°	PN25	ANSI 300	44	74	F07/SW17	F10/SW22
3"	90°	PN25	ANSI 300	44	74	F07/SW17	F10/SW22
4"	90°	PN25	ANSI 300	66	111	F07/SW17	F10/SW22
5"	90°	PN16	ANSI 150	111	184	F10/SW22	F12/SW27
6"	90°	PN16	ANSI 150	111	184	F10/SW22	F12/SW27
8"	90°	PN16	ANSI 150	155	258	F12/SW27	F14/SW36
10"	90°	PN16	ANSI 150	266	443	F12/SW27	F14/SW36
12"	90°	PN16	ANSI 150	664	1106	F14/SW36	F16/SW46

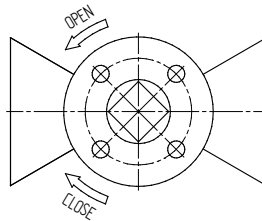

Ball Sector Valve with reduced Kvs-values

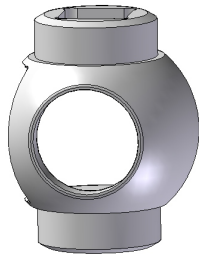

100%

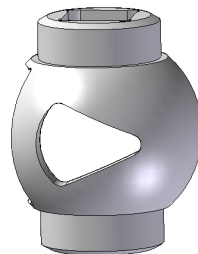

reduced to
63%

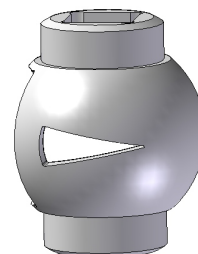

reduced to
25%

Dimensions KS2 without actuator (with mounting kit ISO 5211)

Sealing of the bearing shaft with PTFE-packing

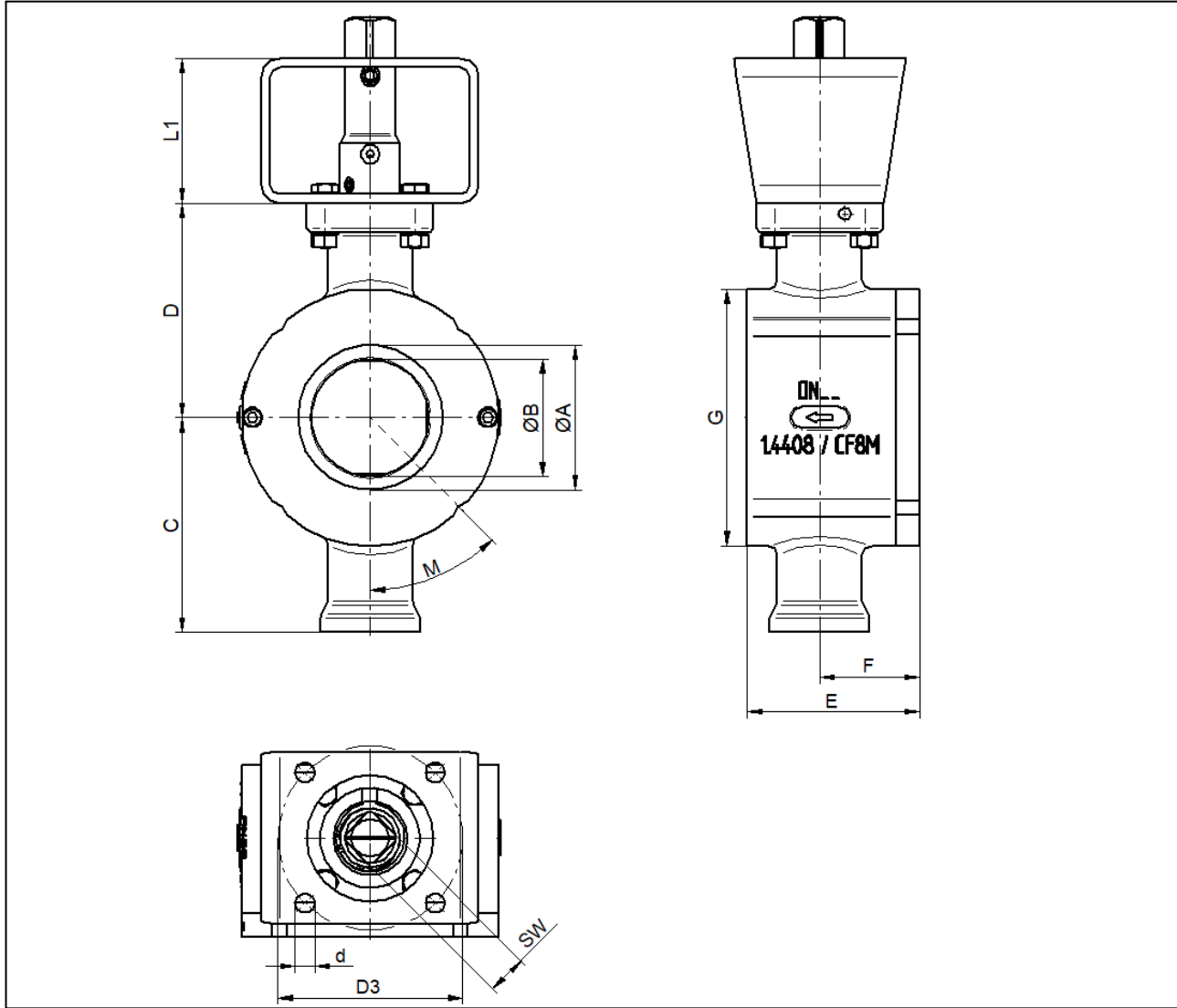

DN	A	B	C	D	E	F	G	L1	series 1				DIN ISO 5211	series 2				weight [lbs]
									SW	d	D3	L1		SW	d	D3	DIN ISO 5211	
1"	0.98	0.79	3.35	3.35	1.97	1.02	2.95	2.36	0.43	0.22	1.65	F 04	2.36	0.55	0.26	1.97	F 05	4.9
1 1/2"	1.61	1.26	3.62	3.62	2.28	1.22	3.78	2.36	0.55	0.26	1.97	F 05	2.36	0.67	0.35	2.76	F 07	6.6
2"	2.09	1.57	3.74	3.74	2.8	1.5	4.41	2.36	0.55	0.26	1.97	F 05	2.36	0.67	0.35	2.76	F 07	8.4
2 1/2"	2.56	1.97	4.55	4.55	3.35	1.93	5.08	2.36	0.67	0.35	2.76	F 07	3.15	0.87	0.43	4.02	F 10	14.1
3"	3.15	2.56	4.67	4.67	3.74	2.17	5.59	2.36	0.67	0.35	2.76	F 07	3.15	0.87	0.43	4.02	F 10	15.9
4"	3.94	3.15	5.1	5.1	4.41	2.44	6.85	2.36	0.67	0.35	2.76	F 07	3.15	0.87	0.43	4.02	F 10	24.3
5"	3.94	4.92	6.99	6.99	5.83	3.35	7.87	3.15	0.87	0.43	4.02	F 10	3.15	1.06	0.53	4.92	F 12	44.1
6"	5.91	4.72	7.36	7.36	6.69	3.74	8.66	3.15	0.87	0.43	4.02	F 10	3.15	1.06	0.53	4.92	F 12	50.7
8"	7.87	6.1	8.5	8.5	8.27	4.72	10.85	3.15	1.06	0.53	4.92	F 12	3.15	1.42	0.67	5.51	F 14	88.2
10"	9.84	7.68	9.53	9.53	10.63	5.71	13.31	3.15	1.06	0.53	4.92	F 12	3.15	1.42	0.67	5.51	F 14	145.5

Dimensions in inch

Dimensions KS2 with standard actuator

Sealing of the bearing shaft with PTFE-packing

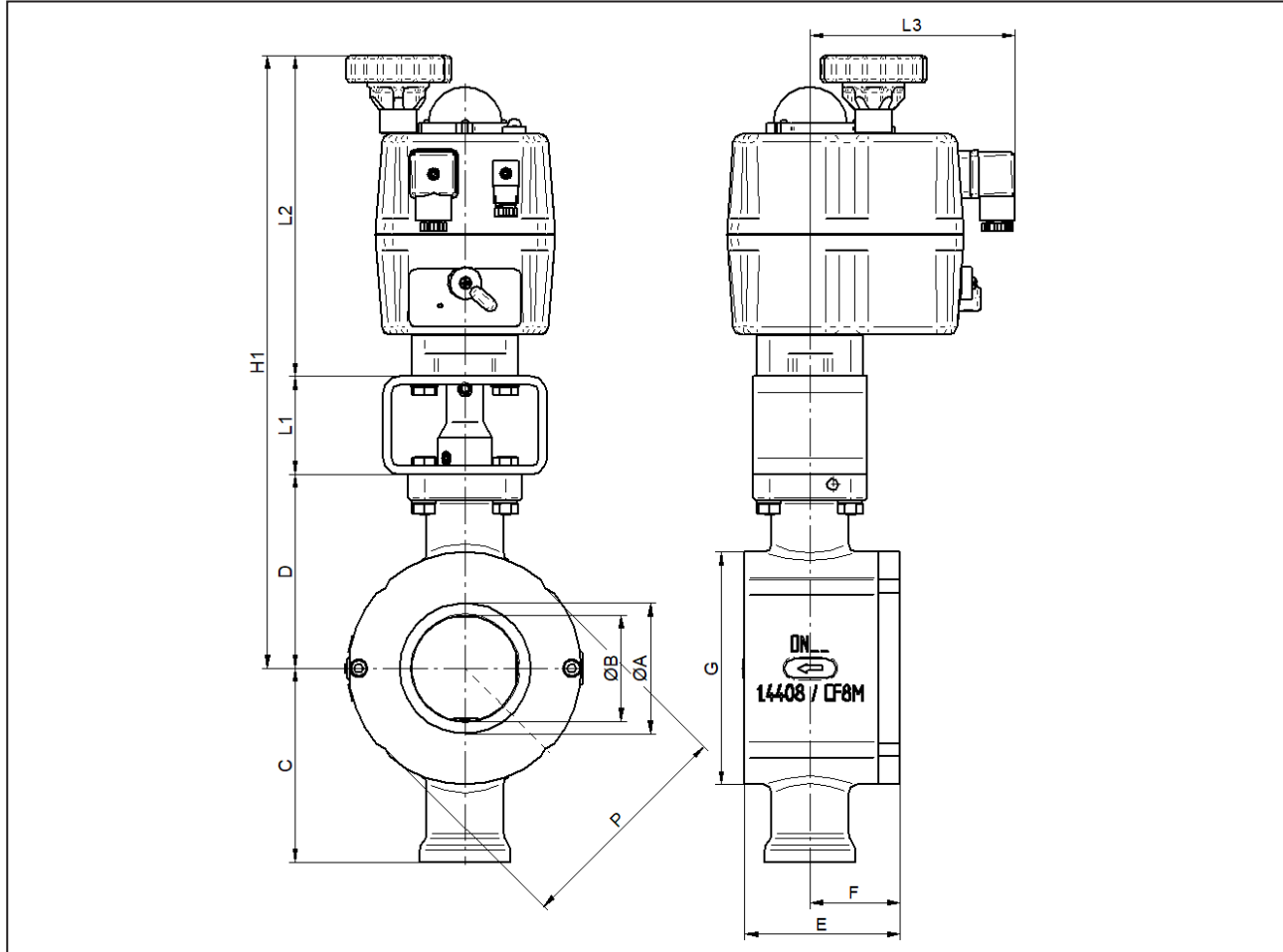

Size	A	B	C	D	E	F	L1	L2	L3	H	Weight [lbs]
1"	0.98	0.79	3.35	3.35	1.97	1.02	2.36	6.65	5.12	12.36	11
1 1/2"	1.61	1.26	3.62	3.62	2.28	1.22	2.36	7.72	5.12	13.7	14
2"	2.09	1.57	3.74	3.74	2.8	1.5	2.36	7.72	5.12	13.82	15
2 1/2"	2.56	1.97	4.55	4.55	3.35	1.93	2.36	7.72	5.12	14.65	24
3"	3.15	2.56	4.67	4.67	3.74	2.17	2.36	7.72	5.12	14.76	37
4"	3.94	3.15	5.1	5.1	4.41	2.44	3.15	10	5.04	18.27	40
5"	3.94	4.92	6.99	6.99	5.83	3.35	3.15	10	5.04	20.16	60
6"	5.91	4.72	7.36	7.36	6.69	3.74	3.15	10	5.04	20.51	66
8"	7.87	6.1	8.5	8.5	8.27	4.72	3.15	10	5.04	21.65	106

Size	PN					ANSI 150				ANSI 300			
	PN	G	P	M	Amount	G	P	M	Amount	G	P	M	Amount
1"	PN40	2.95	2.87	1.77	4	2.95	2.66	1.77	4	3.11	2.87	1.77	4
1 1/2"	PN40	3.78	3.7	1.77	4	3.78	3.43	1.77	4	3.9	3.7	1.77	4
2"	PN40	4.41	4.17	1.77	4	4.41	4.17	1.77	4	4.41	0	0	0
2 1/2"	PN25	5.08	0	0	0	5.08	4.92	1.77	4	5.08	0	0	0
3"	PN25	5.59	0	0	0	5.59	5.43	1.77	4	5.91	0	0	0
4"	PN25	6.85	6.46	0.89	8	6.93	0	0	0	7.17	0	0	0
5"	PN16	7.87	7.64	0.89	8	7.87	7.64	1.77	8	---	---	---	---
6"	PN16	8.66	0	0	0	8.66	0	0	0	---	---	---	---
8"	PN16	10.85	0	0	0	10.85	0	0	0	---	---	---	---

Text and pictures are not binding. We reserve the right to alter the equipment.