

Ball Sector Valve 4030

DN 25 up to DN 300

Motorvalve for the control of neutral and aggressive fluids

- DN 25 up to DN300
- High Kvs-values up to 3840
- Excellent control characteristics
- Suitable for abrasive media
- Easily exchangeable seat ring
- Low maintenance
- Actuators can be easily fitted
- Efficient and easy to install
- optional with face to face dimension acc. ANSI ISA 75.08.02



Technical Information Valve

Design	DN 25 - DN 250 flangeless wafer type DN 300 flange connection	
Nominal sizes	DN 25 up to DN 300	
Body material	cast parts turned parts	1.4408 (CF8M) 1.4404 (316L)
Bearing material	high temperature plain bearing (Iglidur Z)	
Connection to the actuator	mounting kit DIN/ISO 5211	
Nominal pressure	DN 25 - DN 50 DN 80 - DN100 DN 150 - DN 300	PN40 (for flanges PN 10 - PN 40), ANSI150, ANSI300 PN25 (for flanges PN 10 - PN 25), ANSI150, ANSI 300 PN16 (for flanges PN 10 - PN 16), ANSI150
Fluid Temperature	-40°C up to +220°C	according to the sealings
Ambient temperature	-20°C up to +70°C special version on request	according to the acuator
Vacuum	up to 50 mbar abs.	
Characteristic	almost equal percentage	
Rangeability	100:1	
Classification DIN EN ISO15848-1	series KS2, DN25-DN250: ISO FE-BH-CC3-SSA0-t(-40°C/+220°C)-PN40-ISO 15848-1 series KS1; DN300: ISO FE-BH-CC-SSA0-t(RT)-PN16-ISO 15848-1	

Working pressure max.

Nominal size DN	maximum differential pressure (delta p)									
	seat ring PTFE			seat ring PEEK				seat ring Stellite		
	up to 80°C	120°C	170°C	up to 80°C	120°C	170°C	220°C	up to 80°C	170°C	220°C
	bar	bar	bar	bar	bar	bar	bar	bar	bar	bar
25-50	25	16	6	40	40	25	16	40	40	25
80-100	16	12	5	25	25	16	10	25	25	16
150-300	16	12	4	16	16	12	8	16	16	12

Actuators for mounting according DIN/ISO5211

Temperature limits

Seat ring	Sealing seating									
	Viton		EPDM		NBR		FFKM		PFA-Silicon	
	Tmin [°C]	Tmax [°C]	Tmin [°C]	Tmax [°C]	Tmin [°C]	Tmax [°C]	Tmin [°C]	Tmax [°C]	Tmin [°C]	Tmax [°C]
PTFE	-15	170	-40	140	-30	100	-15	170	-45	170
PEEK	-15	200	-40	140	-30	100	-15	220	-45	220
Stellite	-15	200	-40	140	-30	100	-15	220	-45	220

Leakage

Seat ring	Ball sector	Leakage	
		Amount of the max. Kvs-value	class acc. EN 60534-4: (IEC 60534-4)
PTFE or PEEK	stainless steel polished		VI
PTFE or PEEK	stainless steel hard chrome plated	5x10 ⁻⁷	IV-S1
Stellite	stainless steel, hard chrome plated + lapped	5x10 ⁻⁶	IV-S1

Kvs-Values

DN	Kvs-Value reduced to					
	100%	63%	40%	25%	16%	6,3%
25	25	12,7	7,9	5,3	3,6	1,45
40	70	40	25			
50	109	65	41			
65	190					
80	300					
100	390					
125	756					
150	810					
200	1365					
250	2220					
300	3840					

Operation time / 90° with standard actuator

DN	operation time / 90° [s]
25	9
40	13
50	13
65	29
80	29
100	34
125	58
150	58
200	58

Torques and mounting kits

for retrofitting actuators

DN	rotation angle nominal	max. nominal pressure PN	max. nominal pressure ANSI	req. torque [Nm]		mounting kit ISO 5211 diagonal square shaft	
				on/off-operation	control operation	series 1	series 2
25	90°	PN40	ANSI 300	15	25	F04/SW11	F05/SW14
40	90°	PN40	ANSI 300	30	50	F05/SW14	F07/SW17
50	90°	PN40	ANSI 300	30	50	F05/SW14	F07/SW17
65	90°	PN25	ANSI 300	60	100	F07/SW17	F10/SW22
80	90°	PN25	ANSI 300	60	100	F07/SW17	F10/SW22
100	90°	PN25	ANSI 300	90	150	F07/SW17	F10/SW22
125	90°	PN16	ANSI 150	150	250	F10/SW22	F12/SW27
150	90°	PN16	ANSI 150	150	250	F10/SW22	F12/SW27
200	90°	PN16	ANSI 150	210	350	F12/SW27	F14/SW36
250	90°	PN16	ANSI 150	360	600	F12/SW27	F14/SW36
300	90°	PN16	ANSI 150	900	1500	F14/SW36	F16/SW46

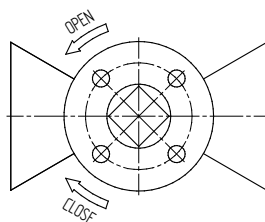

Ball Sector Valve with reduced Kvs-values

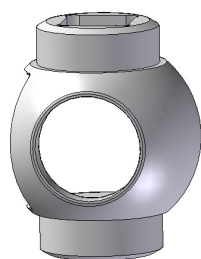

100%

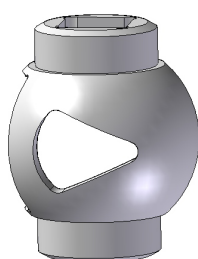

reduced to
63%

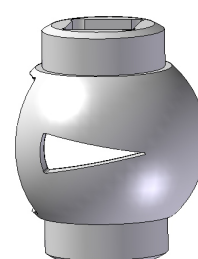

reduced to
25%

Dimensions KS2 without actuator (with mounting kit ISO 5211)

Sealing of the bearing shaft with PTFE-packing

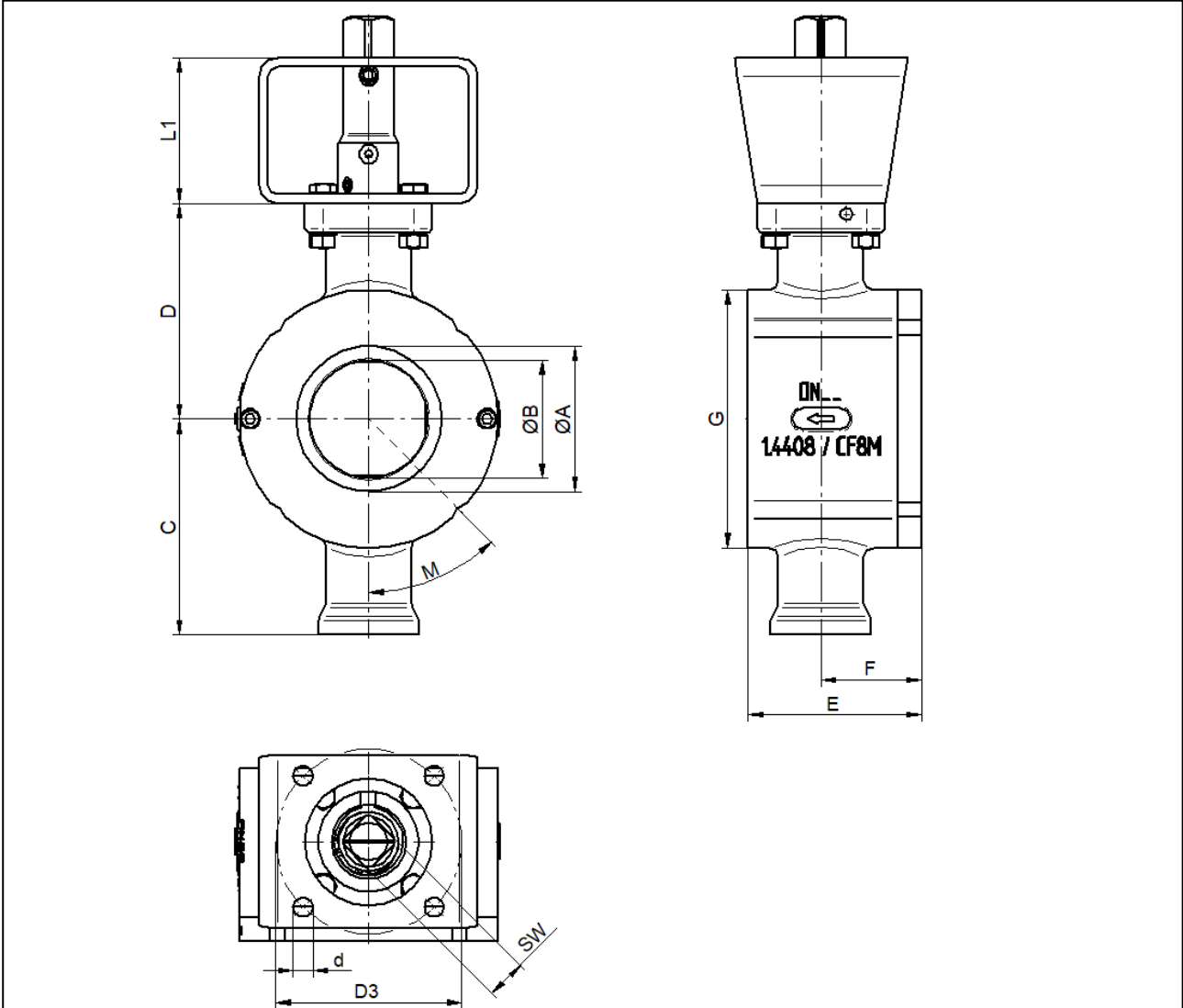

DN	A	B	C	D	E	F	G	L1	series 1				series 2				weight [kg]	
									DIN ISO 5211	L1	SW	d	D3	DIN ISO 5211	L1	SW		d
25	25	20	85	85	50	26	75	60	11	5,5	42	F 04	60	14	6,6	50	F 05	2,2
40	41	32	92	92	58	31	96	60	14	6,6	50	F 05	60	17	9	70	F 07	3
50	53	40	95	95	71	38	112	60	14	6,6	50	F 05	60	17	9	70	F 07	3,8
65	65	50	115,5	115,5	85	49	129	60	17	9	70	F 07	80	22	11	102	F 10	6,4
80	80	65	118,5	118,5	95	55	142	60	17	9	70	F 07	80	22	11	102	F 10	7,2
100	100	80	129,5	129,5	112	62	174	60	17	9	70	F 07	80	22	11	102	F 10	11
125	100	125	177,5	177,5	148	85	200	80	22	11	102	F 10	80	27	13,5	125	F 12	20
150	150	120	187	187	170	95	220	80	22	11	102	F 10	80	27	13,5	125	F 12	23
200	200	155	216	216	210	120	275	80	27	13,5	125	F 12	80	36	17	140	F 14	40
250	250	195	242	242	270	145	338	80	27	13,5	125	F 12	80	36	17	140	F 14	66

Dimensions in mm

Dimensions KS2 with standard actuator

Sealing of the bearing shaft with PTFE-packing

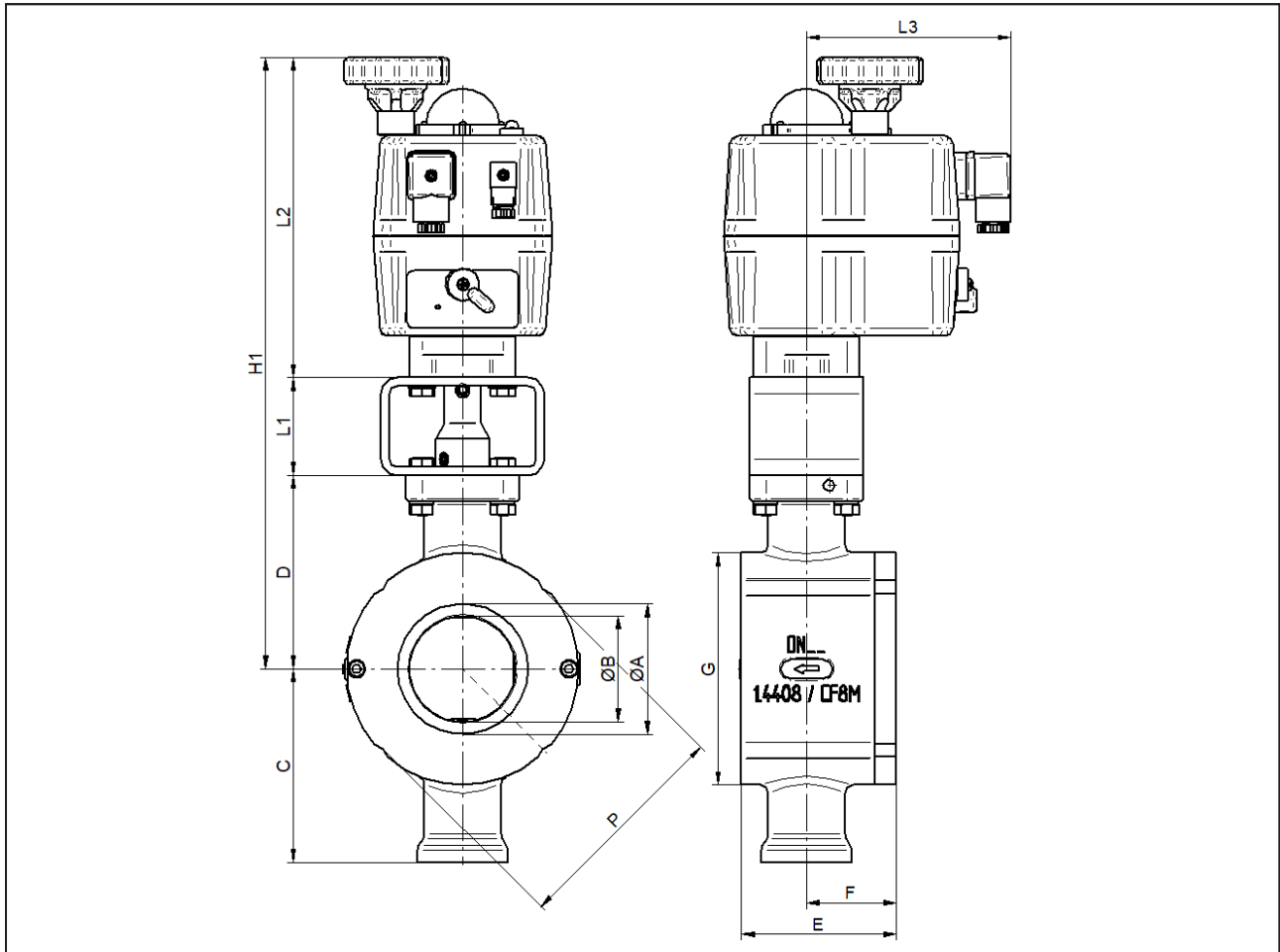

DN	A	B	C	D	E	F	L1	L2	L3	H	Weight [kg]
25	25	20	85	85	50	26	60	169	130	314	4,8
40	41	32	92	92	58	31	60	196	130	348	6,2
50	53	40	95	95	71	38	60	196	130	351	6,9
65	65	50	115,5	115,5	85	49	60	196	130	372	11
80	80	65	118,5	118,5	95	55	60	196	130	375	17
100	100	80	129,5	129,5	112	62	80	254	128	464	18
125	100	125	177,5	177,5	148	85	80	254	128	512	27
150	150	120	187	187	170	95	80	254	128	521	30
200	200	155	216	216	210	120	80	254	128	550	48

DN	PN					ANSI 150				ANSI 300			
	PN	G	P	M	Amount	G	P	M	Amount	G	P	M	Amount
25	PN40	75	73	45	4	75	67,6	45	4	79	73	45	4
40	PN40	96	94	45	4	96	87	45	4	99	94	45	4
50	PN40	112	106	45	4	112	106	45	4	112	0	0	0
65	PN25	129	0	0	0	129	125	45	4	129	0	0	0
80	PN25	142	0	0	0	142	138	45	4	150	0	0	0
100	PN25	174	164	22,5	8	176	0	0	0	182	0	0	0
125	PN16	200	194	22,5	8	200	194	45	8	---	---	---	---
150	PN16	220	0	0	0	220	0	0	0	---	---	---	---
200	PN16	275	0	0	0	275	0	0	0	---	---	---	---

Dimensions in mm